

## KATIE TABLE LOOM

A folding 8 shaft 30cm (12ins) table loom

Dear Weaver,

Congratulations on purchasing your new Katie Table Loom. For 90 years we have been making craft equipment for spinners and weavers around the world and have now produced over 600,000 wheels and looms. We are sure you will enjoy the convenience and portability of this loom. Thank you for choosing Ashford.

Your Katie Table Loom has been lacquered prior to assembly. If desired, an application of Ashford Finishing Wax Polish may further enhance its appearance.

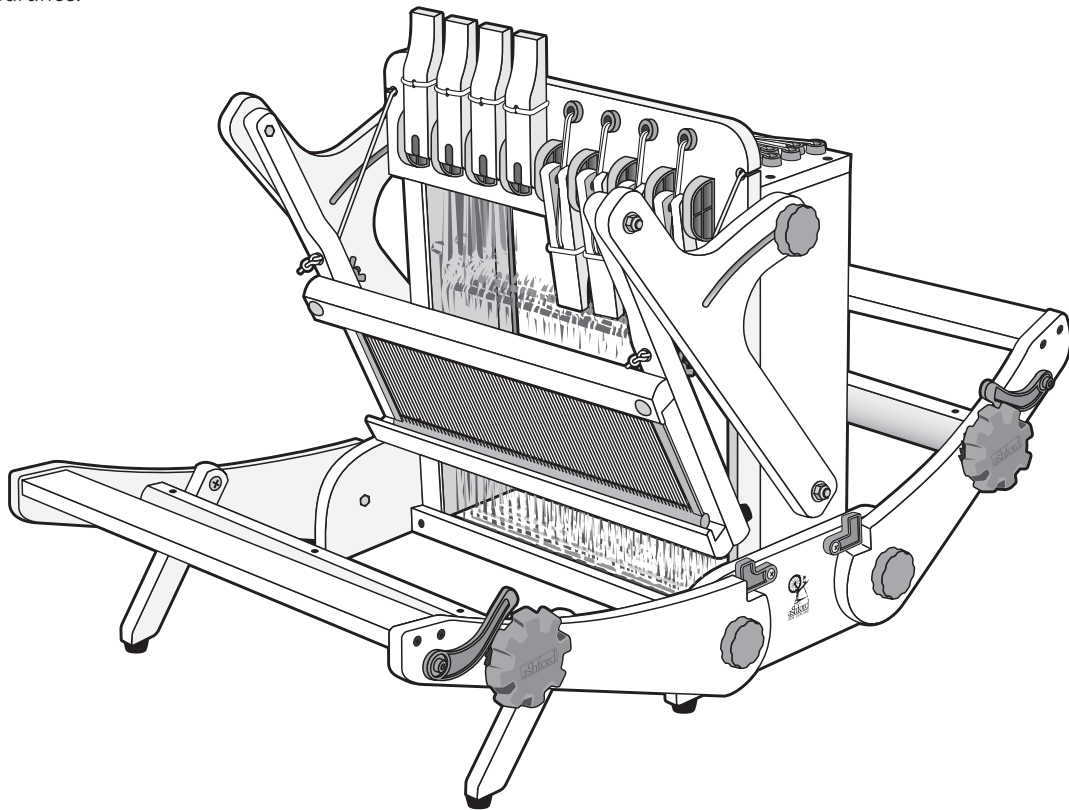

### To unfold your loom

**Step 1:** Loosen the knobs securing the front beam and fold down.

Engage the locks, lift the front beam and tighten the knobs.

**Step 2:** Lift the front of the loom slightly and fold the feet out.

**Step 3:** Loosen the knobs securing the back beam and fold down.

Engage the locks, lift the back beam and tighten the knobs.

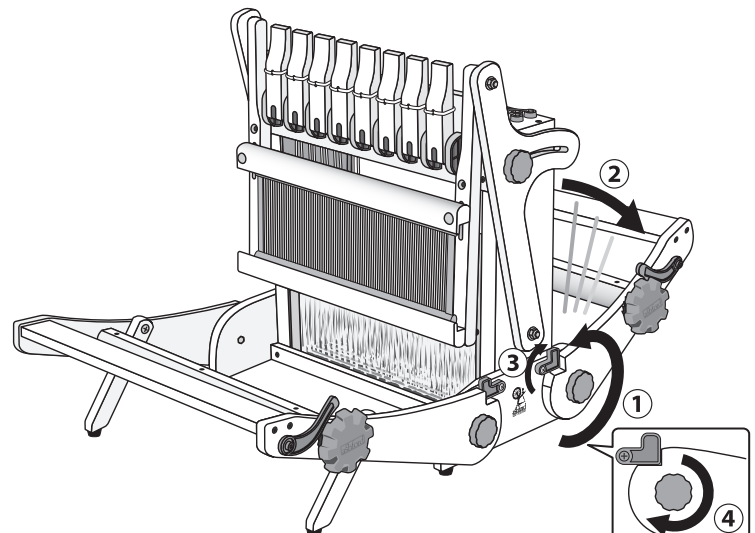
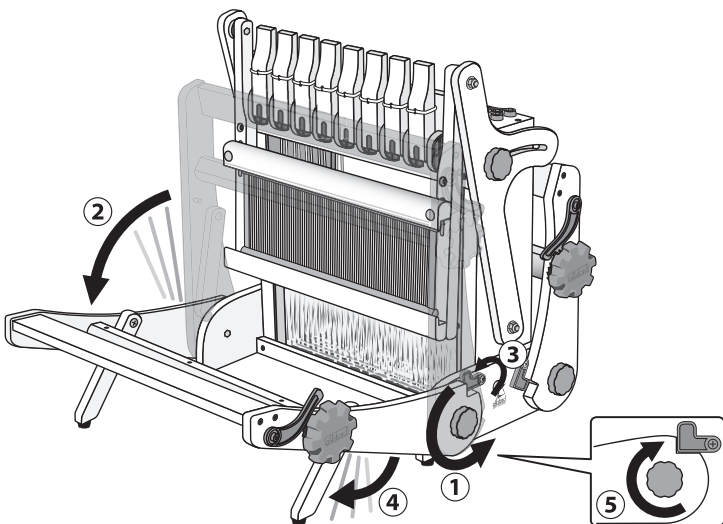

**Step 4:** Loosen knobs securing the beater supports, slide the beater completely forward and tighten the knobs.

**NOTE:** To avoid potential damage to the top beater rail we have packed it separately. Please attach it to the beater arms with 2 x bolts, washers and wing nuts. Make sure the wing nuts are parallel to the beater rails to ensure the loom folds.

**Step 5:** Tie a knot in the ends of the bungee cords and thread them through the holes in the beaters. Tie a knot in the other end and locate them into the slots in the castle front. Adjust the position of the knot to increase or decrease the tension.

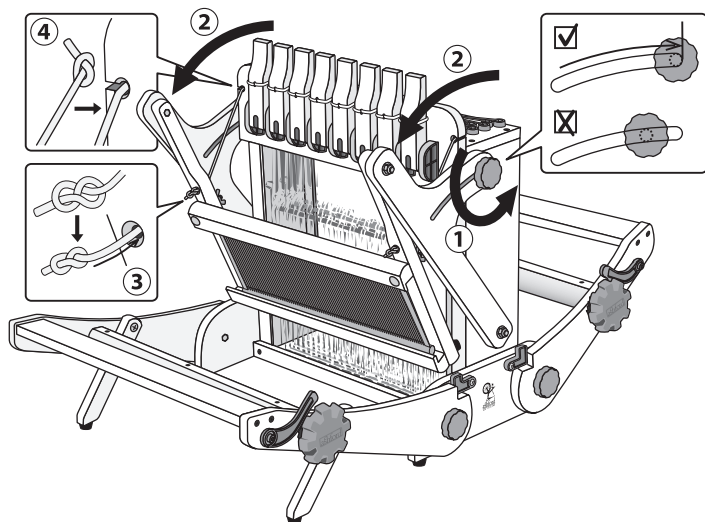

**Step 6:** Push the levers down and check the gap between the shafts and the castle top is approx. 1cm (1/2ins) on both sides. Adjust the height as necessary by moving the Texsolv cord in the lever or on the screw head in the shaft end.

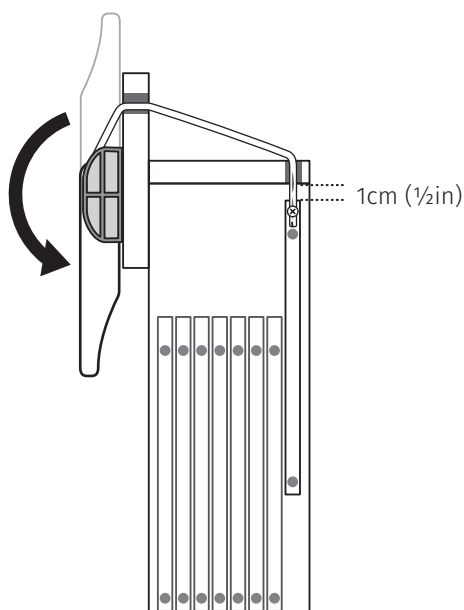

**Step 7:** Attach the front and back warp sticks with the cotton string supplied with your loom as illustrated.

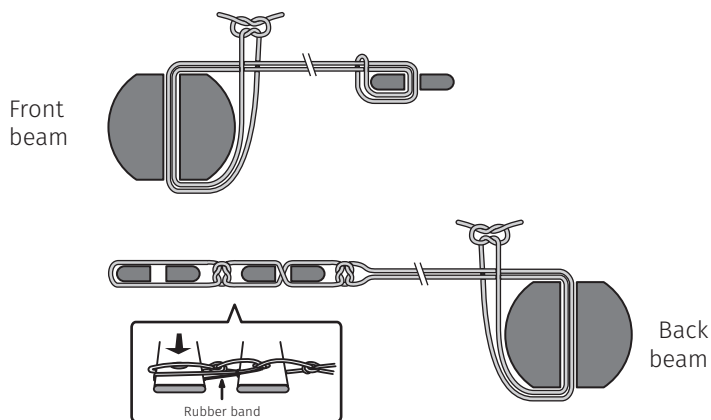

**Step 8:** To fold the loom, lift all the levers and reverse steps 4, 3, 2 and 1.

**Warping Instructions:** Refer to the Learn To Weave on the Table Loom Booklet. Please note the weaving project in the booklet is for a project on a 40cm (16ins) four shaft loom. For a project on the Katie Table Loom please start with the project notes enclosed.

**IMPORTANT**

When you need to advance your weaving, only advance it so the fell (the edge of the weaving at the last weft pick) is level with the legs. If you advance it too far your beater will hit the bottom roller.

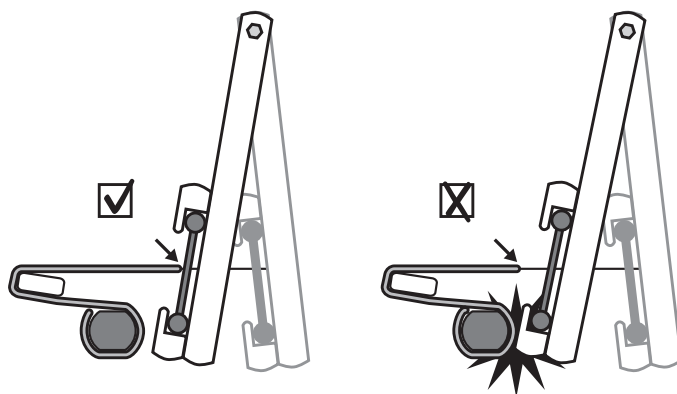

**Recommended Accessories:**

- Raddle Kit 30cm (12ins)
- Warping Frame – either 11m (37ft) or 4.5m (14 1/2ft)

**Other Accessories:**

- Boat Shuttle 29cm (11 1/2ins), Boat Shuttle 38cm (15ins)
- Boat Shuttle Bobbin Winders Wood and Metal
- Stick Shuttles
- Stainless Steel Reeds - 6, 8, 10, 12 and 16 DPI
- Texsolv Heddles - Bundles of 40
- Yarn Stand

**Recommended Reading:**

*The Ashford Book of Weaving Patterns from Four to Eight Shafts* by Elsa Krogh.

**Happy Weaving!**

# Project notes for the Katie Table Loom

Please read in conjunction with the Learn to Weave on the Table Loom booklet.

## YOUR FIRST PROJECT – TABLE RUNNER

### You will need:

Warping frame, Ruler or yarn gauge, Tape measure, Raddle, String, Scrap yarn, Scissors

Warp and weft yarn – Ashford Cotton 5/2 (100% cotton; 848m/927yds; 200gms/7oz), Bleached White 300gm (101/2oz), Twilight Grey 60gm (2.1oz) and Black 110gm (3.8oz).

### Here's how:

Sett – 20 ends per inch (8 ends per cm)

No. of ends: 240

Warp length: 2yds (2m)

Width in reed: 12ins (30cm)

Finished size (hemmed and washed): 9¾ x 46in (25 x 116cm)

### Weave Structure:

Twill

### Reading the Draft for the Table Runner

Pattern drafts are made of four parts:

1. Threading draft
2. Shafts
3. Liftings
4. Drawdown

#### 1. Threading Draft

This shows the order in which the warp is threaded through the heddle eyes. Threading drafts are read from right to left. For this project, the first warp thread will be threaded through the heddle on shaft one. Two pattern repeats are shown. The bracket below shows how many times to repeat each section.

#### 2. Shafts

Show which shaft to use when threading and lifting.

#### 3. Liftings

This is the order the shafts will be lifted for each weft pick. For this project the first shafts lifted are 1, 3, 5 and 7 by pushing levers 1, 3, 5 and 7 down. Note - lever 1 is on the left and lifts shaft 1, the front shaft.

#### 4. Drawdown

The diagram of the woven cloth produced by the threading and shaft liftings.

## Winding the Warp for the Table Runner

### Warp Colour Order

Using a warping frame wind on the warping threads in the following sequence:

**Remember:** Each trip from the start peg to the end peg and back again will be two warp ends.

1. Wind 20 ends Black
2. Wind 20 ends Grey
3. Wind 60 ends White
4. Wind 40 ends Grey
5. Wind 60 ends White
6. Wind 20 ends Grey
7. Wind 20 ends Black

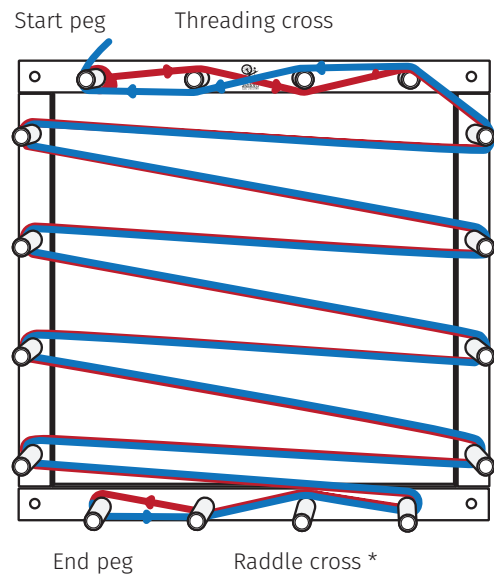

\* The raddle cross will be made after each group of 10 threads.

Continue as per instructions in the Learn to Weave on the Table Loom booklet with the following exception.

Step 11. Release one end of the cross stick. Slide each group of threads off the cross stick and onto the raddle. To ensure warp is centred place first group of threads in the 15th space from the centre pin of the raddle.

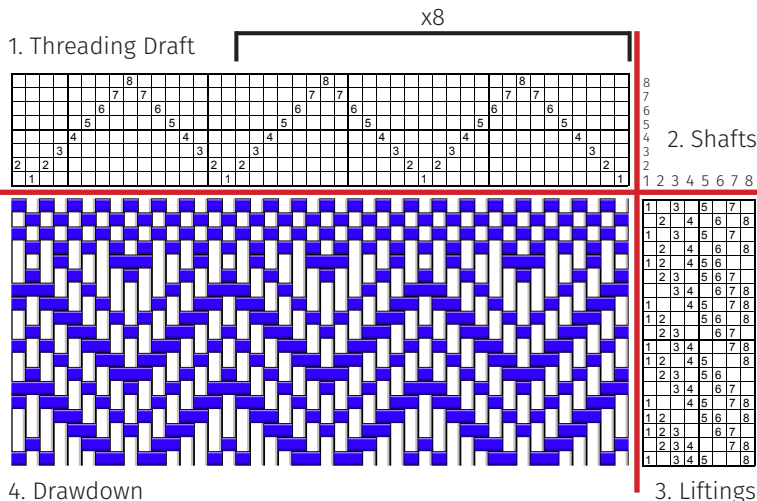

KTL280323V4