

ASHFORD TABLE LOOM - EIGHT SHAFT

410/610/800mm

16/24/32in

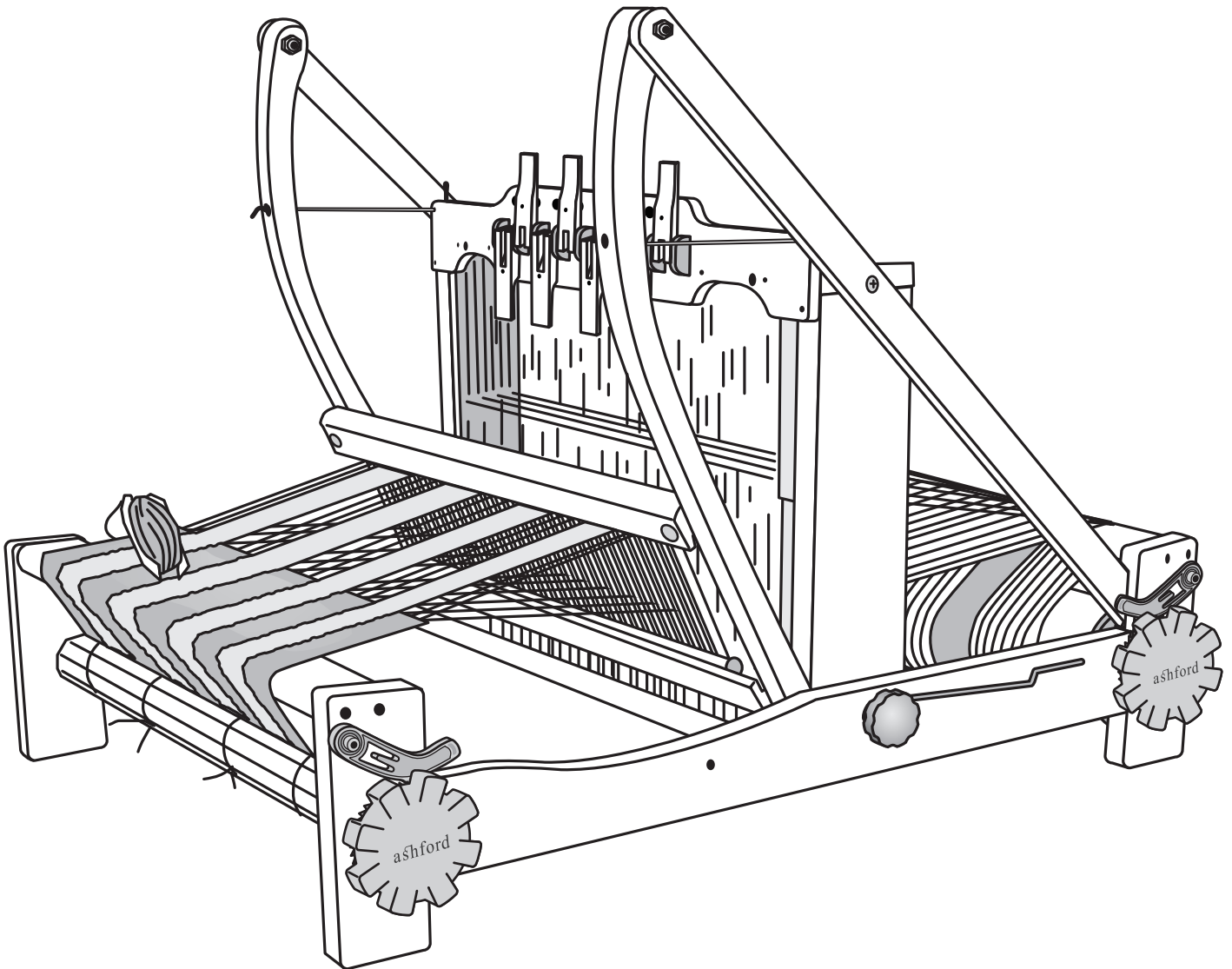

ESTL050923

TOOLS



(including)



HINTS

Before commencing, please read these instructions completely, identify the parts and note the assembly sequence.

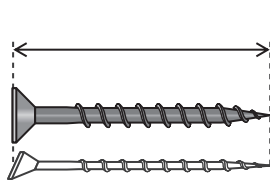

Check hardware against full size illustration.

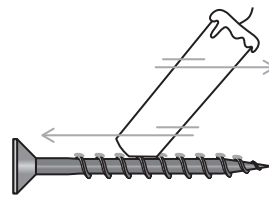

To make assembly easier use candle wax on the screws.

Check!

Check the directions carefully.

1



Attach the castle top to the castle sides with 4 x 38mm (1½") screws. Check that the pilot holes for the castle front are all on the same side.

Attach the bottom cross rails to the bottom of the castle sides with 4 x 30mm (1¼") screws. Check! Only use 30mm (1¼") screws. Longer screws may damage the sides.

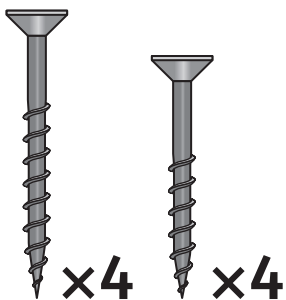

Check!

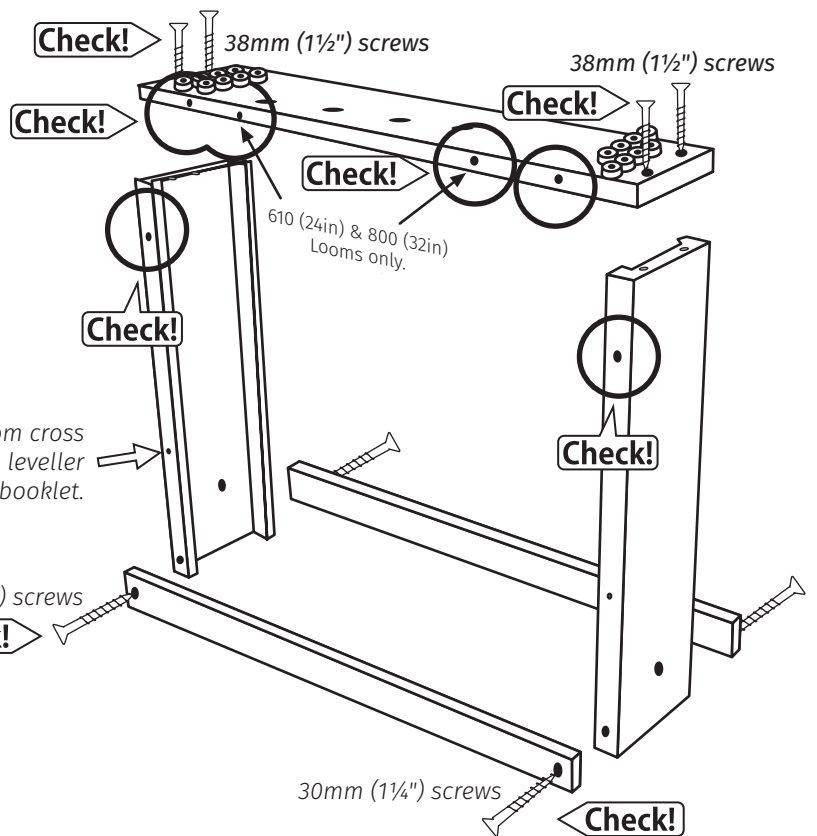
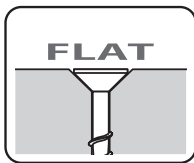

2



Rest the castle front on a table edge for support. Tap the nylon guides into the cord holes from the back.



Check!

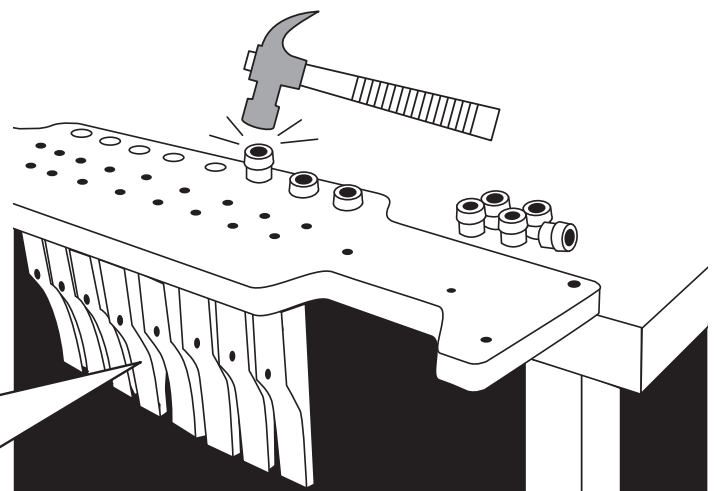
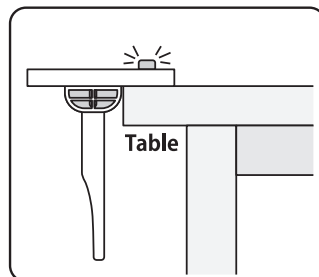



Attach the castle front to the top and sides of the castle with 30mm (1 1/4") screws. Locate the cotter pins into the holes in the castle front. Use these pins to lock the beater in place when threading the reed.

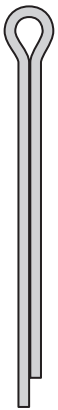
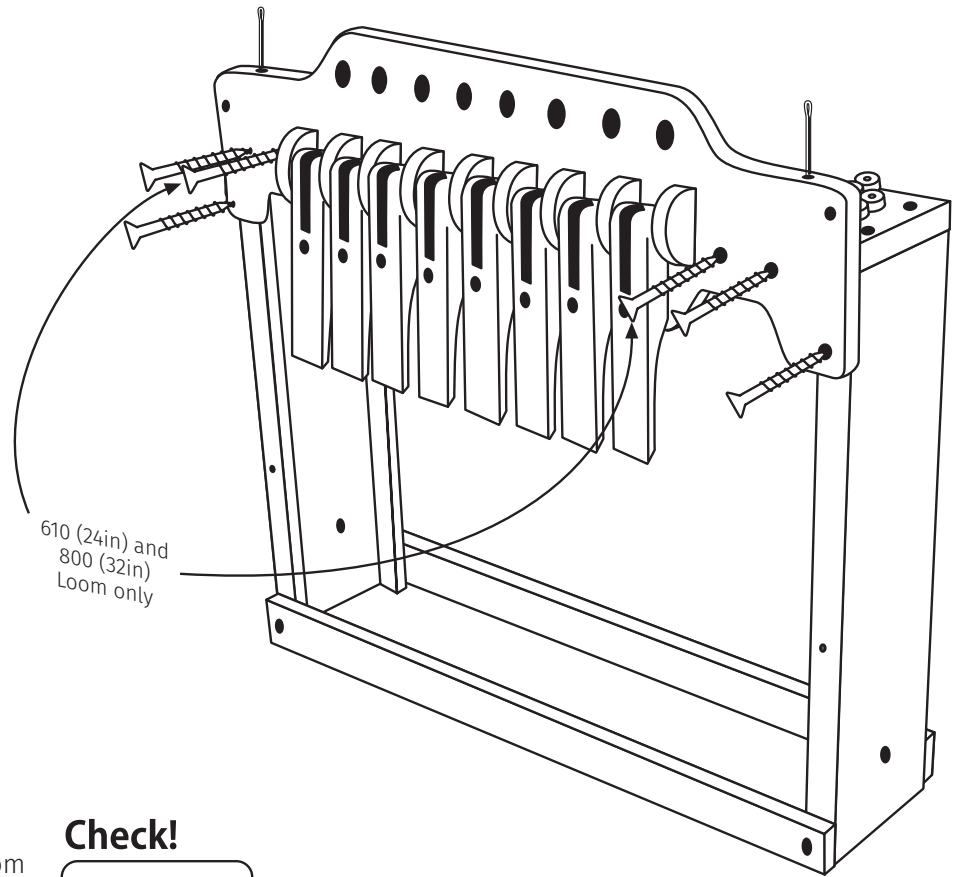

x2

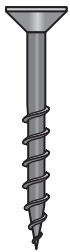

x4

410 (16") Loom

x6

610 (24") and 800 (32") Loom

Check!

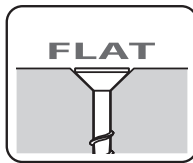

4



NOTE: We have completed this step for you. Remove and discard the wooden protector blocks.

Tap the "clicker pins" for the pawls to the bottom of the holes in the sides. **NOTE:** Both sides are drilled for the pawl.

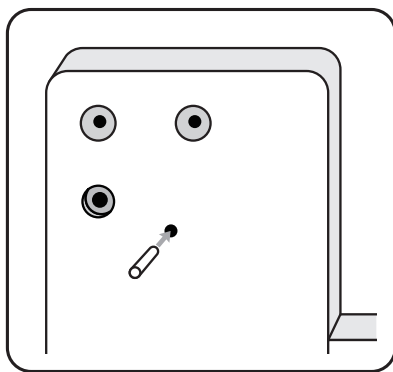

Check!

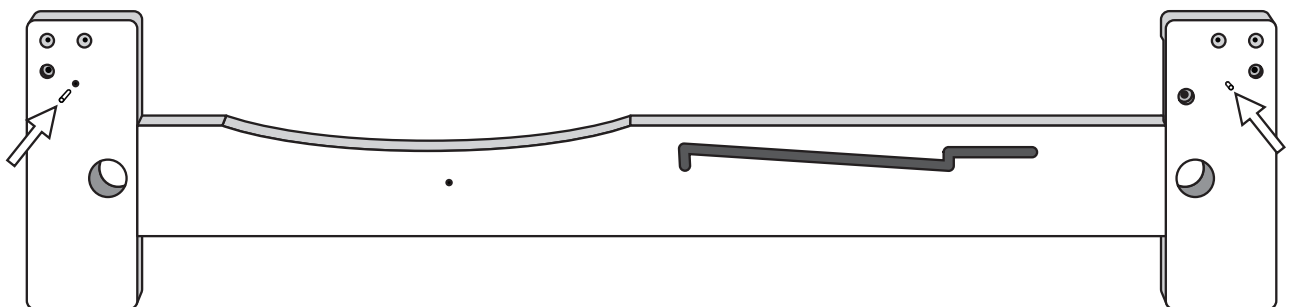
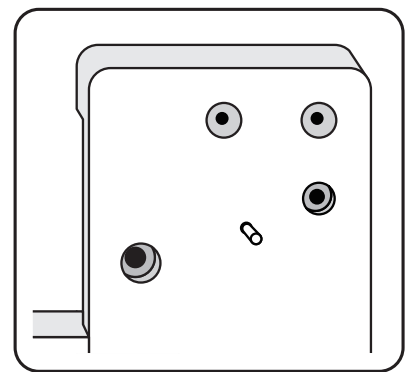
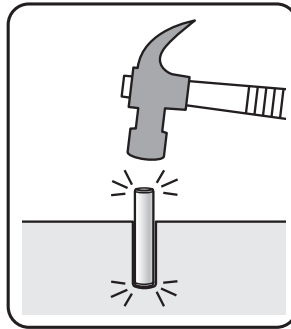

x2



Rest the loom side on a table edge. Tap 25mm (1") hex head bolts through the loom sides. NOTE the head of the bolt MUST be level with or below the surface of the side otherwise the pawl will catch on it.

Check!

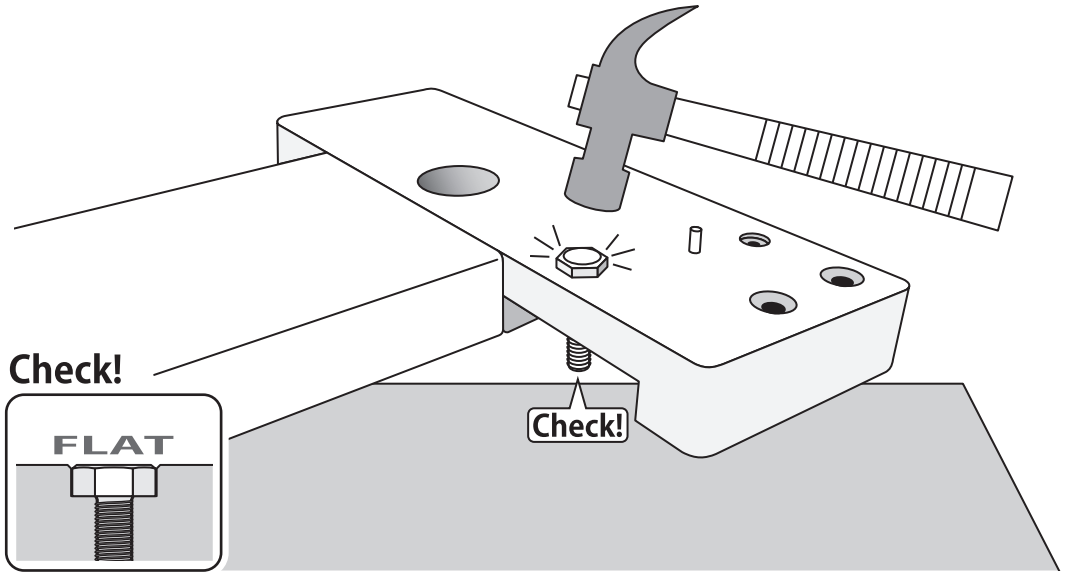
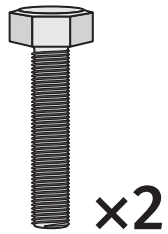
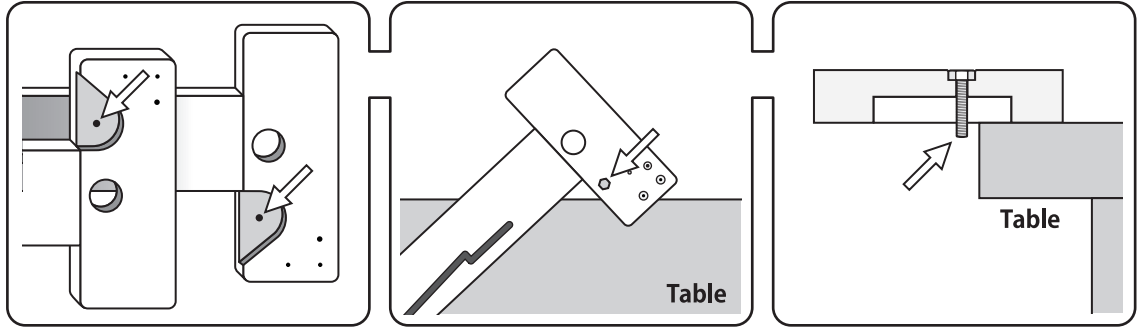

Attach the 2 pawls to the loom side with 30mm (1 1/4") machine screws. NOTE the "clicker pin" fits into the gap in the pawl. Take care to ensure the "clicker pin" does not damage your table. Rub a little candle wax on the thread to make assembly easier. Leave 0.5mm (1/32") gap under the head of the bolt. DON'T over tighten. The pawl should move freely.

Check!

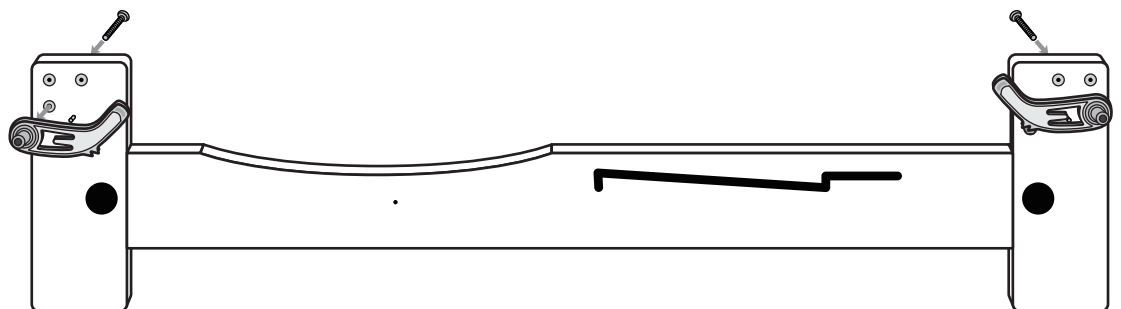
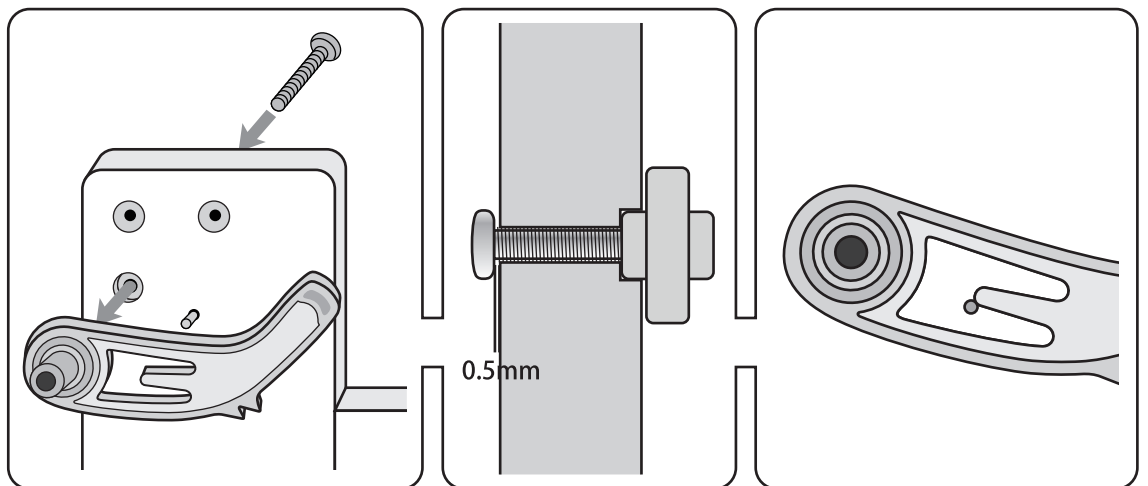

7



Rub candlewax on the ends of the rollers. Place the rollers into the holes in the loom sides with the longer end on the same side as the pawls. Attached the front and back beams to the sides with 50mm (2") screws. Check the round edge of the beams face out.

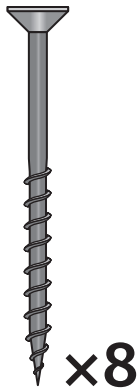

Check!

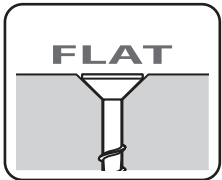

Check!

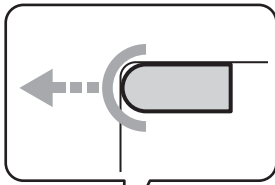

Check!

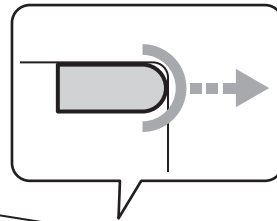

Check!

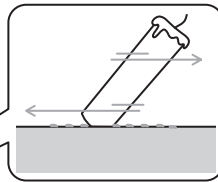

8

Attach the 4 rubber feet with the 12mm (1/2") screws. Attach the support arms to the loom sides after checking they are the correct way around. Secure with washers and nuts. Leave 0.5mm (1/32") gap under the head of the washer and nut.

Check!

Check!

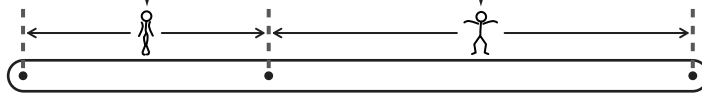

Check!

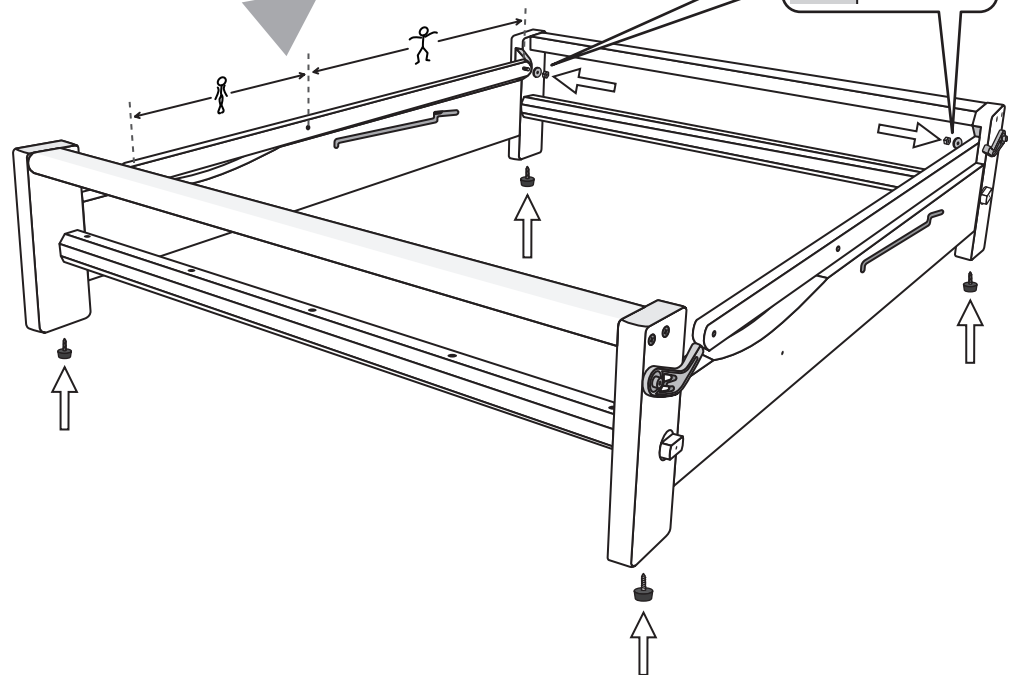
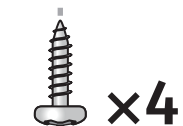
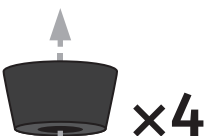
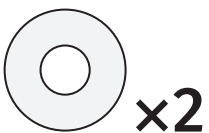
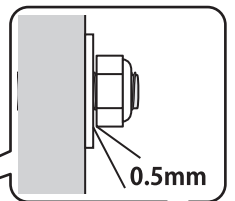

9



Place the cogs onto the ends of the rollers. Check the teeth engage the pawl. THEN secure with washers with small holes and 25mm (1") screws.

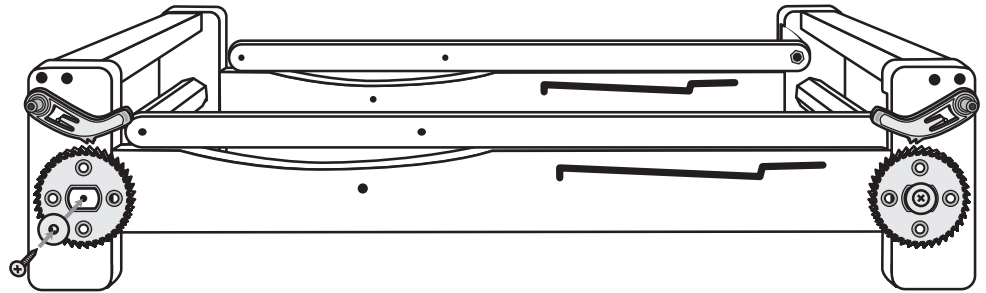
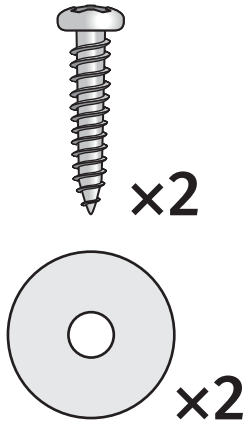
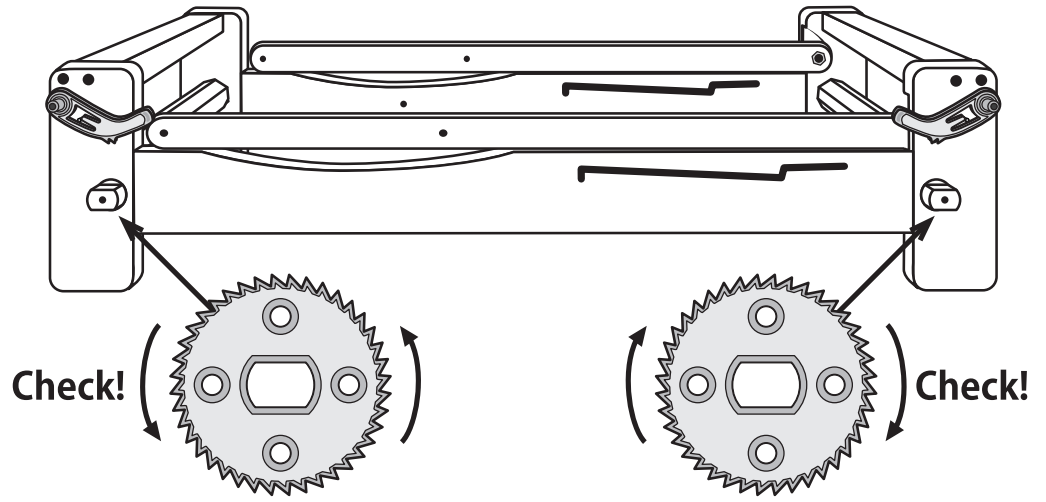

10

Rub candle wax on the 4 pins on the handle. Locate the 4 pins into the 4 holes in the cog. Give the handle a sharp hit with a rubber mallet so it locks down tightly onto the cog. There should be no gap between the handle and the cog. Repeat with other handle.

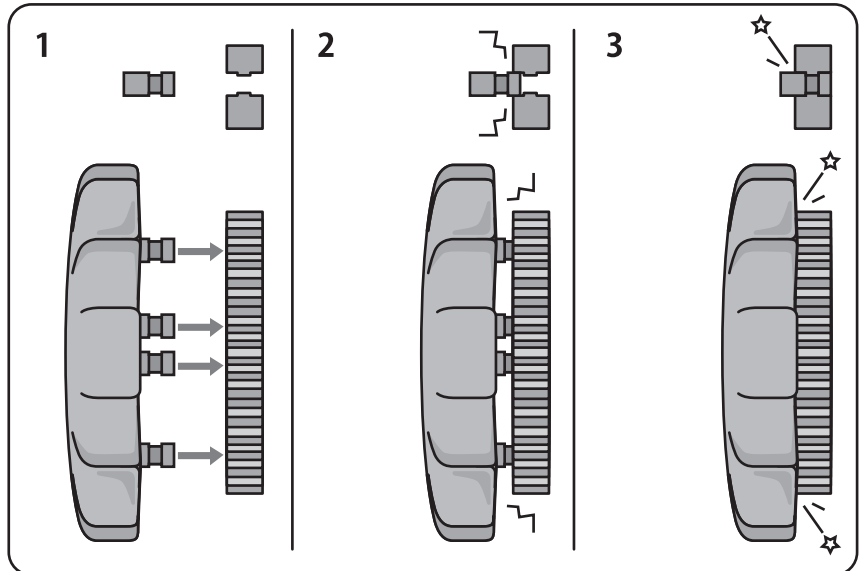
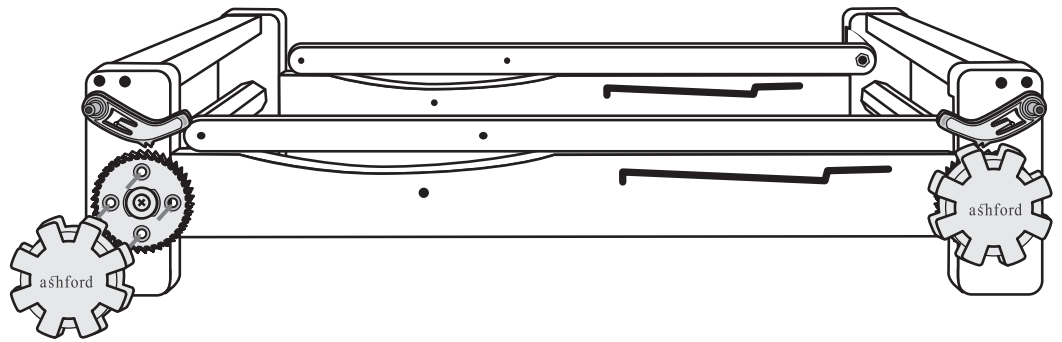

11

Place the castle inside the frame and attach with 40mm (1½") hex head bolts washers and handles. Tap the bolt heads and tighten the knobs until the bolt heads are level or below the surface of the castle otherwise the shafts could catch on them.

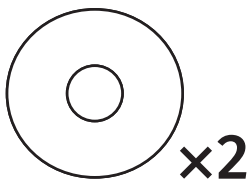
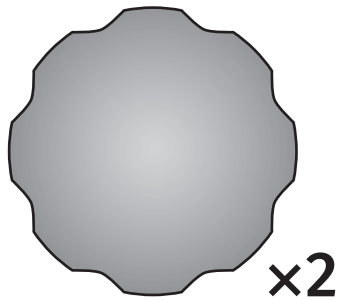
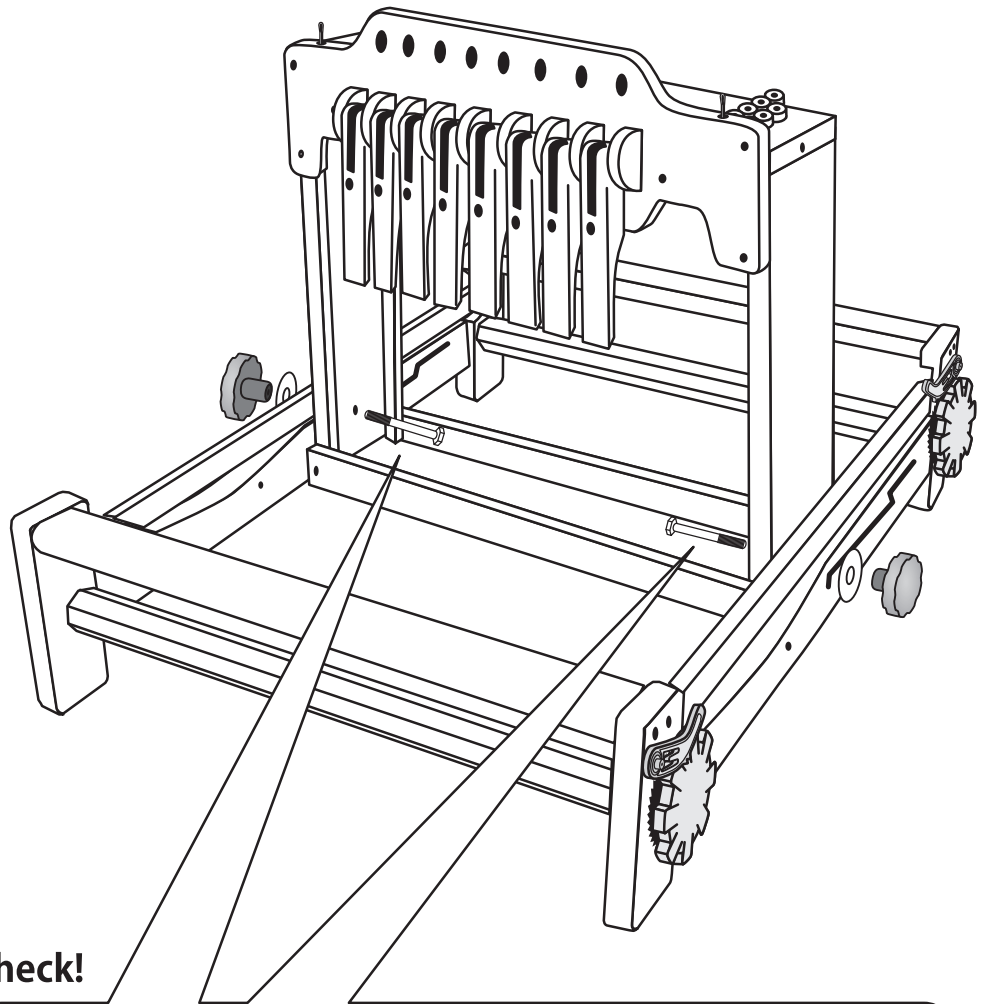
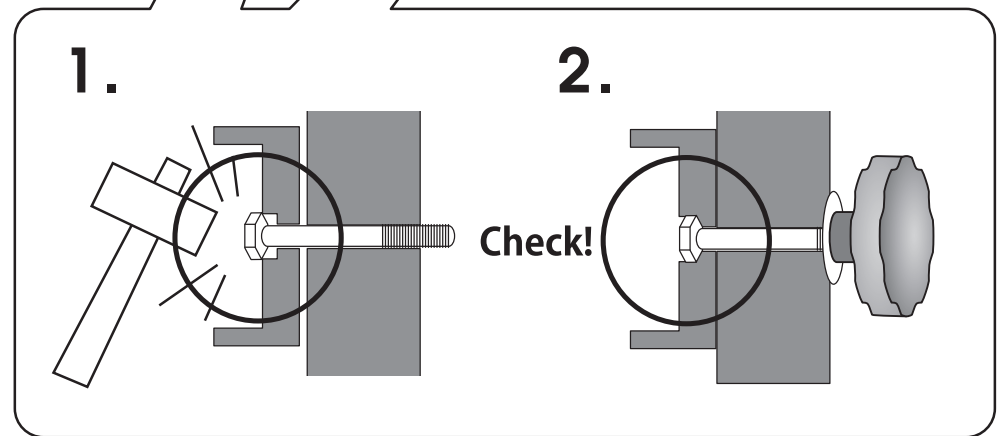
**Check!****12**

Lift the support rails up and attach them to the castle top with 30mm (1¼") screws. Leave a 0.5mm (1/32") gap.

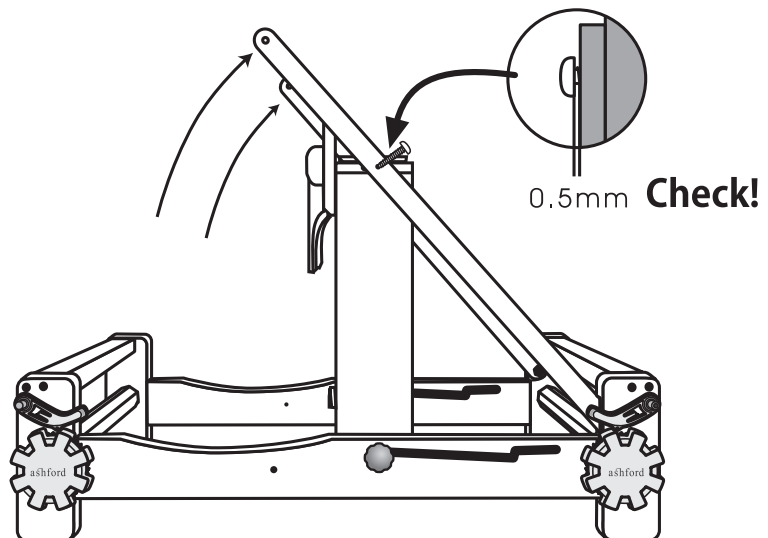



13 Thread the screws into the heddle frame ends using a hand held screwdriver and leave a 5mm ($\frac{3}{16}$ ") gap to loop the texsolv nylon cord over. **Note: Do not use an electric screwdriver as it can drive the screws in too far and crack the heddle frame ends.**

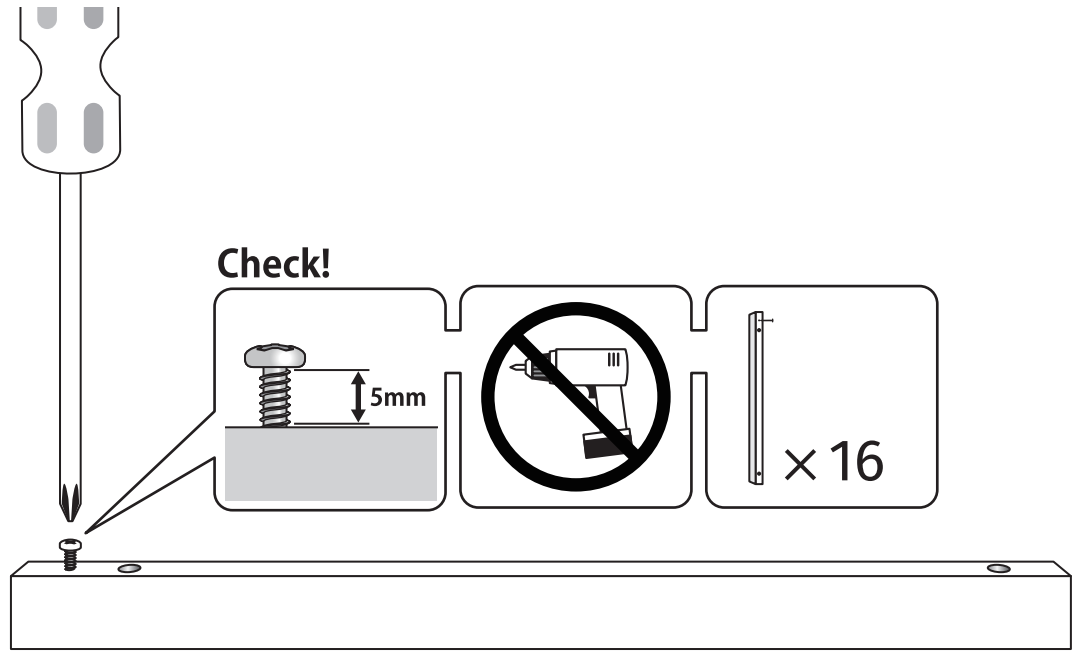

14 Push the metal bars into one heddle frame end, slide a bundle of Texsolv heddles over the bars and push the other end in place. Only then remove the plastic ties. If necessary, cut the Texsolv heddles to separate them. Lay each heddle frame on a flat surface and check the two ends are parallel.

Loom widths	Bundles per shaft
40cm (16")	1
60cm (24")	1½
80cm (32")	2

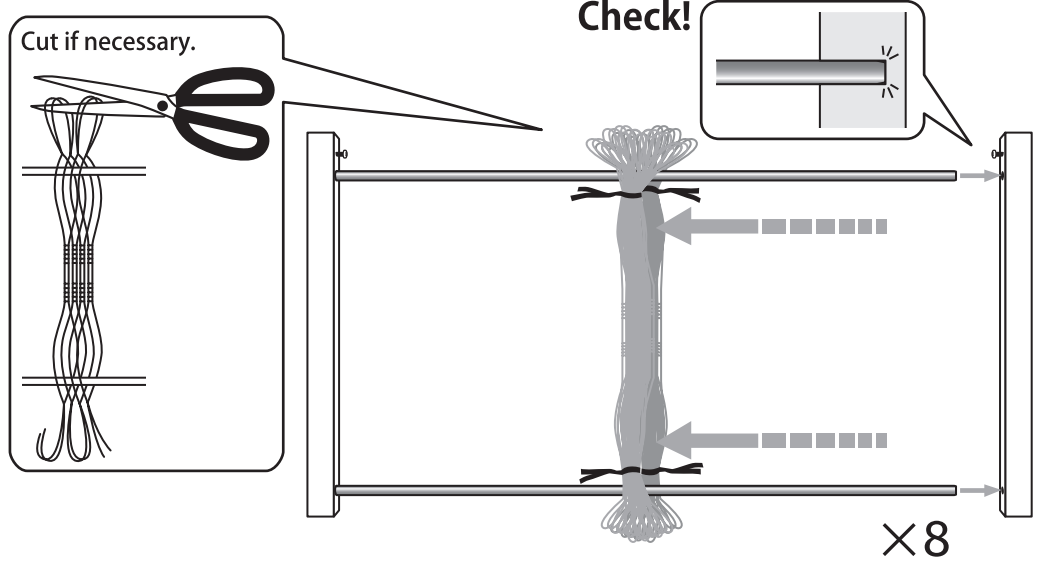

15 Loosen then knobs. Then fold the castle flat. Be careful to hold as directed so you don't jam your fingers. The groove in the side has a two stage path - this is a safety feature so the loom doesn't fold too quickly. DO NOT force the loom from position 2 into position 3. Lift the castle carefully up the groove before sliding back.

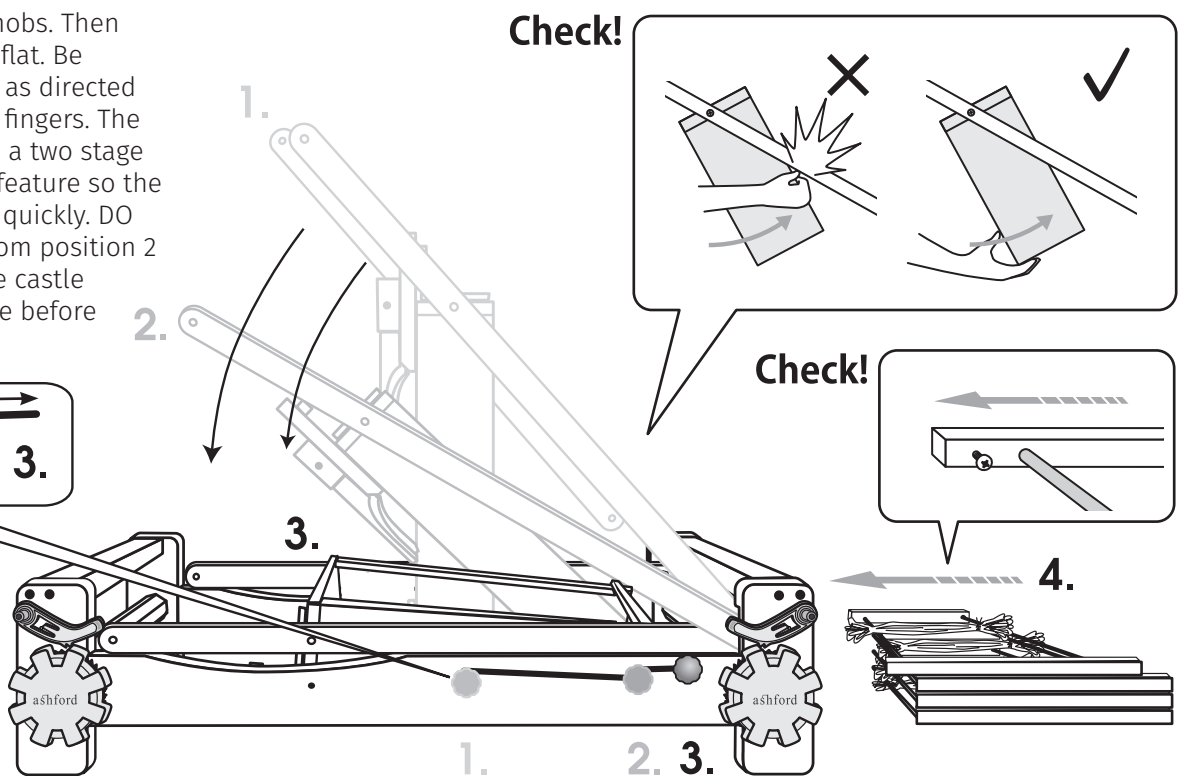
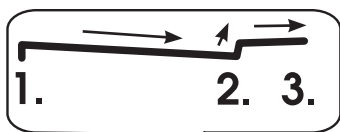

16

Slide the 8 heddle frames into the castle. Hold the heddle frames up to the top of the castle and bring the castle back into the upright position. Then allow the heddle frames to sit down on the table. Attach the lengths of Texsolv cord to the front heddle frame (1) and left lever (1) as shown. Then repeat for the other heddle frames and levers (2, 3, 4, 5, 6, 7, 8). With the levers in the down position adjust the Texsolv cord on both sides of the heddle frames so there is approx. 10mm (1/2") gap under the castle top. Once you have adjusted the position of the heddle frames to your satisfaction you may choose to cut the cord at least 3 slots from the screw head.

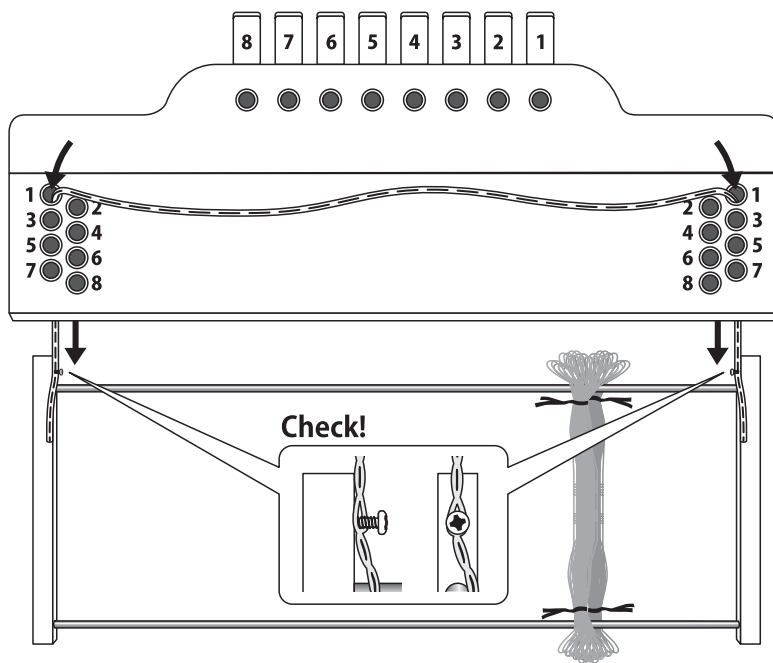

17

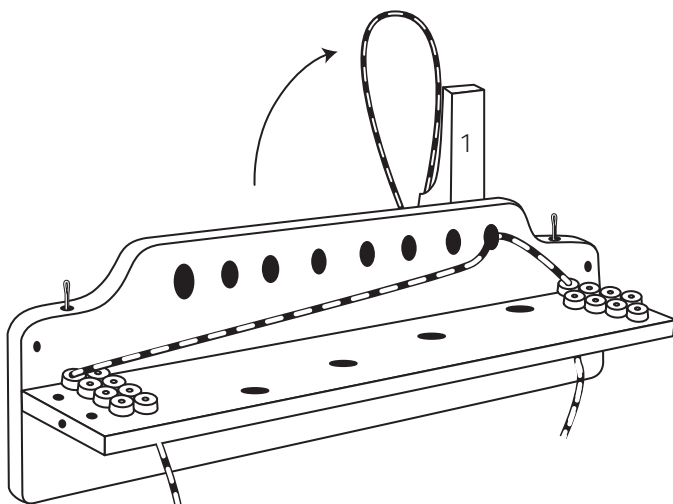
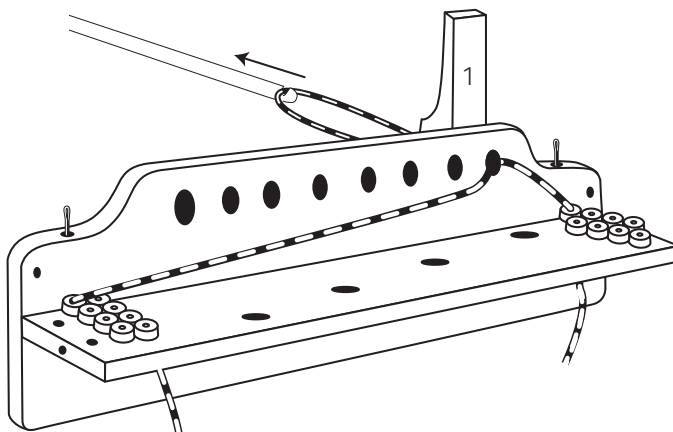
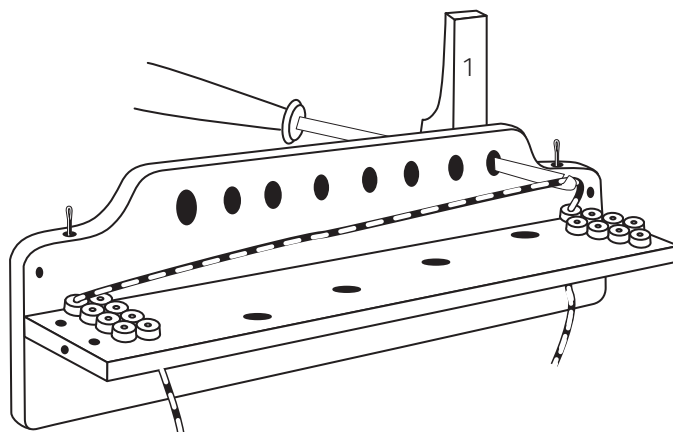
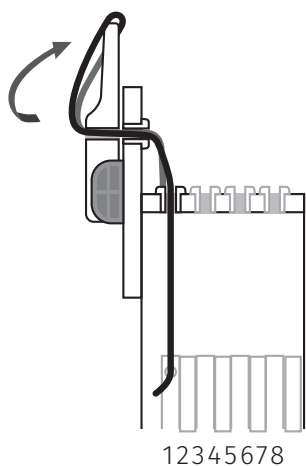
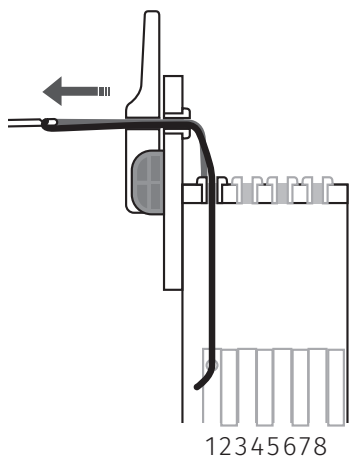
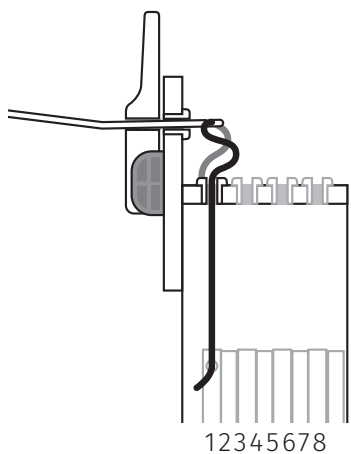

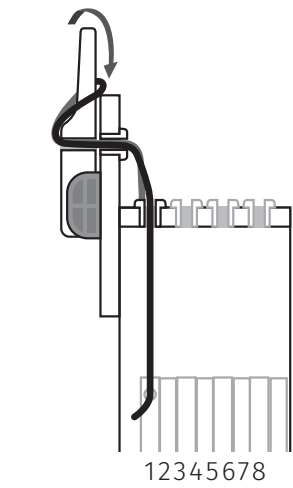

1 2 3 4 5 6 7 8

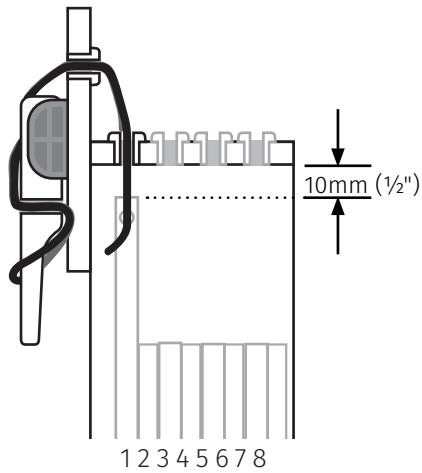
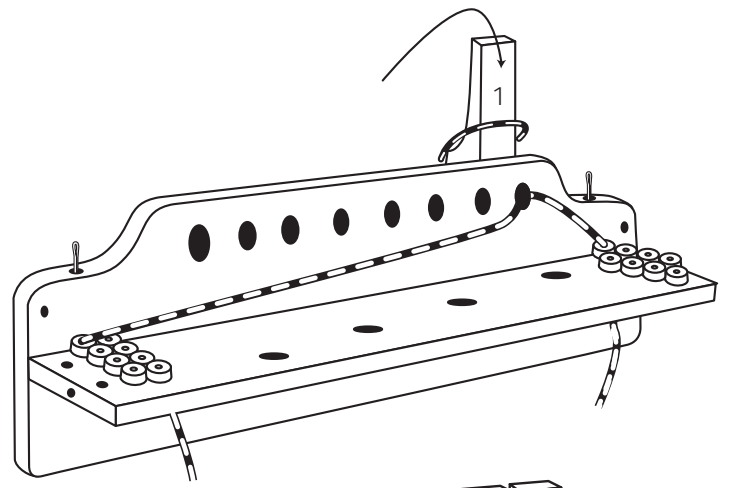
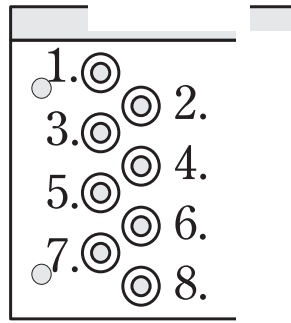

1 2 3 4 5 6 7 8

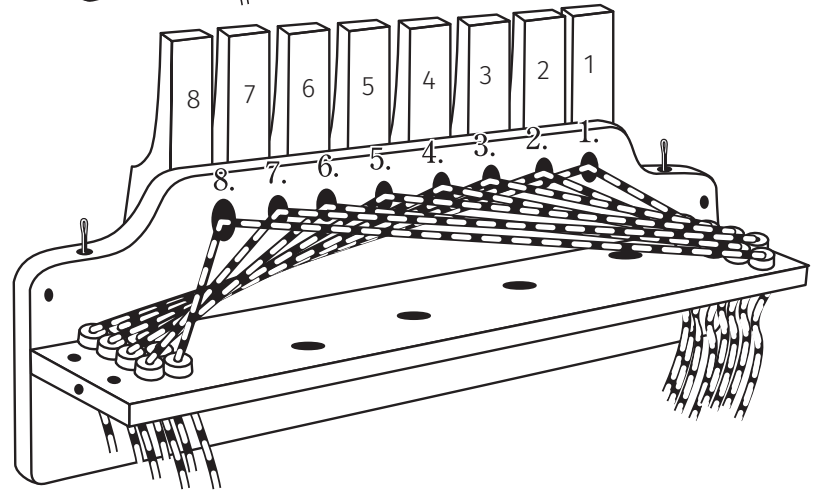

18



Attach rubber buffers to the beater sides with 12mm (1/2") screws. Then assemble the beater frame with 30mm (1 1/4") screws, 50mm (2") bolts, washers and wing nuts. Make sure the wing nuts are parallel to the support rails to ensure the loom folds.

Check!

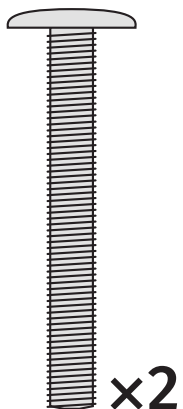
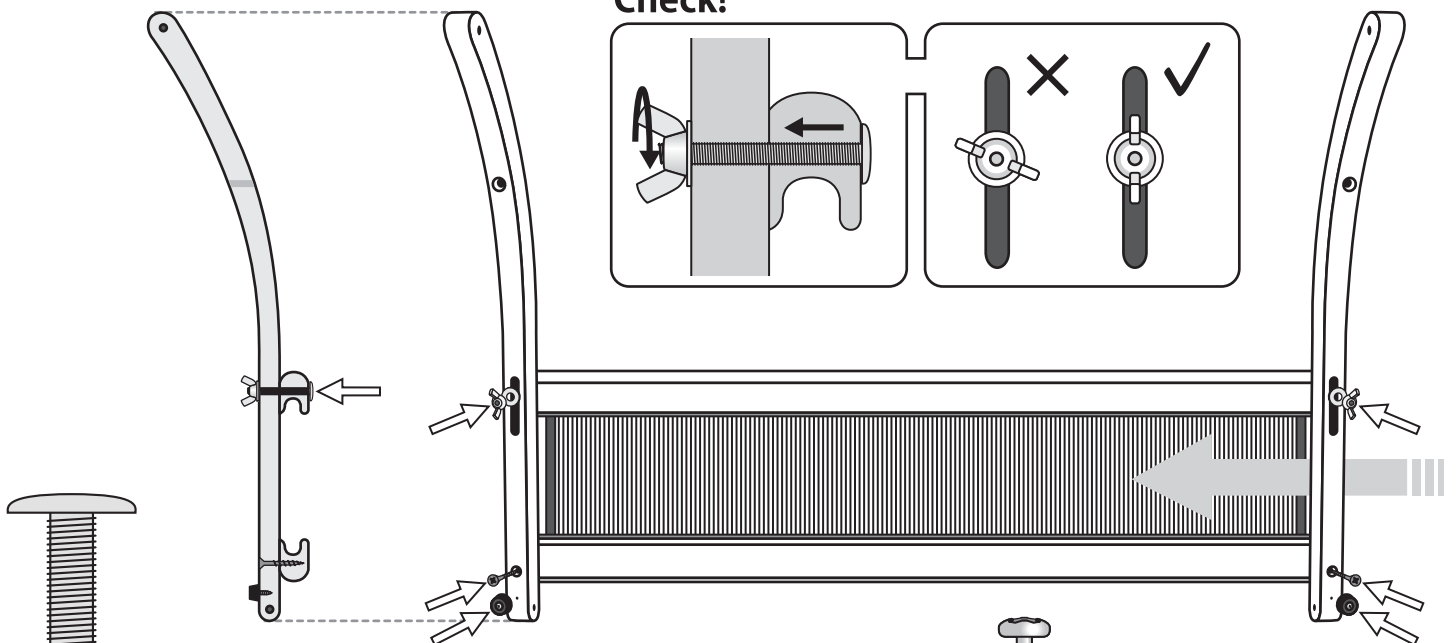
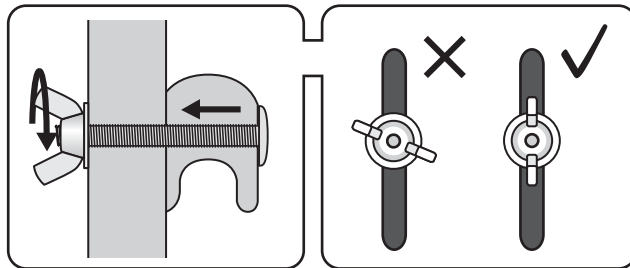

x2

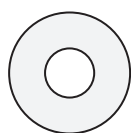

x2



x2

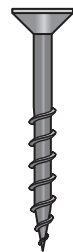

x2



x2



x2

19

Attach beater frame to the support rails. Leave 0.5mm (1/32") gap so the beater can swing freely.

Note: If the beater frame rubs against the loom sides loosen the wing nuts and retighten. Stretchy cord - knot the cord at one end, slide through the hole in the beater support rail, the hole in the castle front and knot the other end. Adjust the position of the knot behind the castle front to increase or reduce the tension so the rubber feet on the beater touch the castle sides

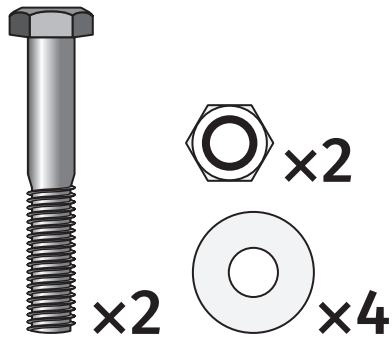

Check!

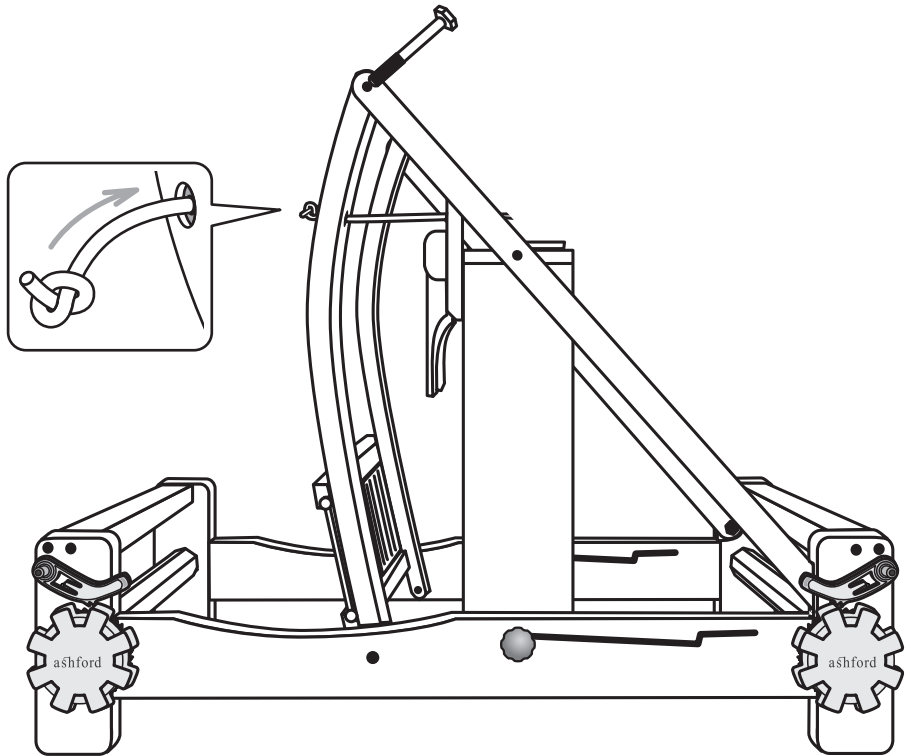
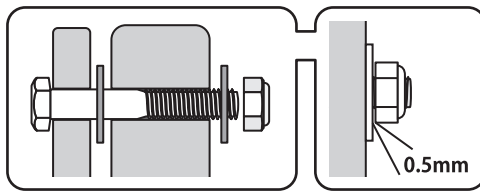

HOW TO FOLD

To fold the castle, loosen the front knobs slightly and completely remove the back knobs. Lift and slide the castle down the slots. When it reaches the safety stop, lift the bottom of the castle again and allow it to fold down completely. Then insert the knobs back through the slot and into holes near the top of the castle side and tighten. This will ensure the castle is well supported when transporting the loom.

Check!

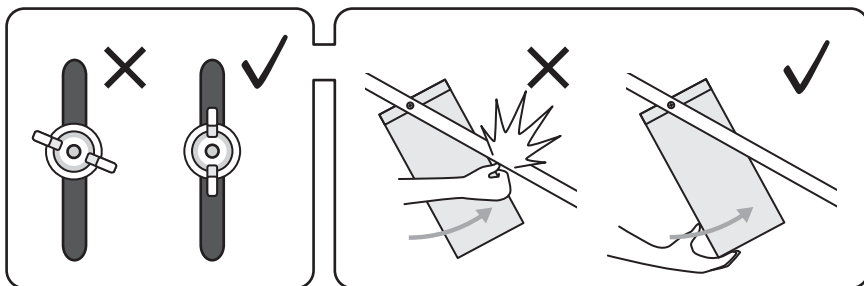

Check!

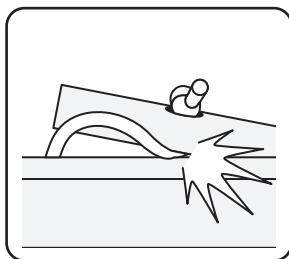

Check!

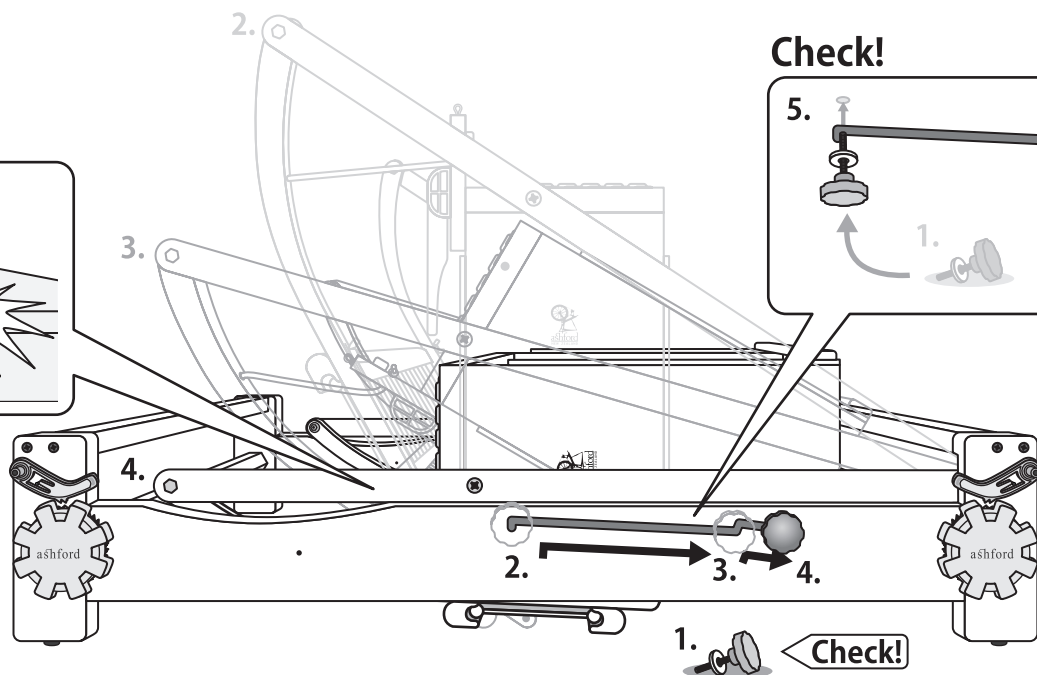
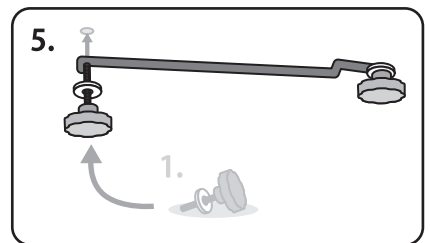

Tying on the front warp stick

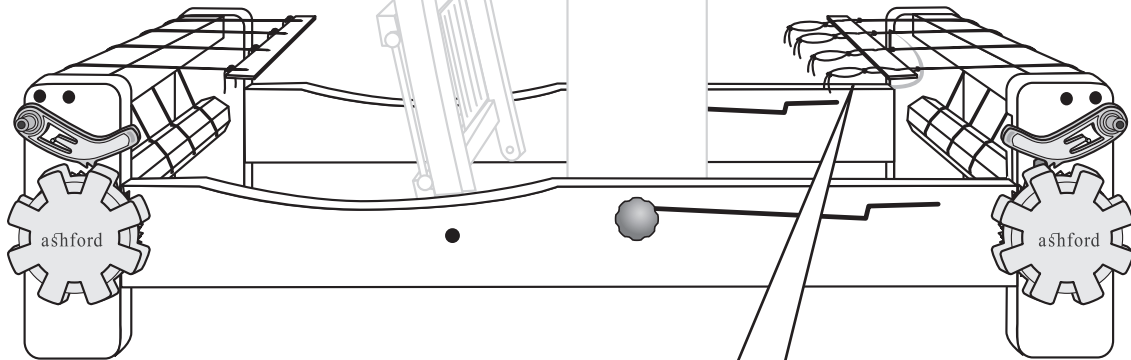
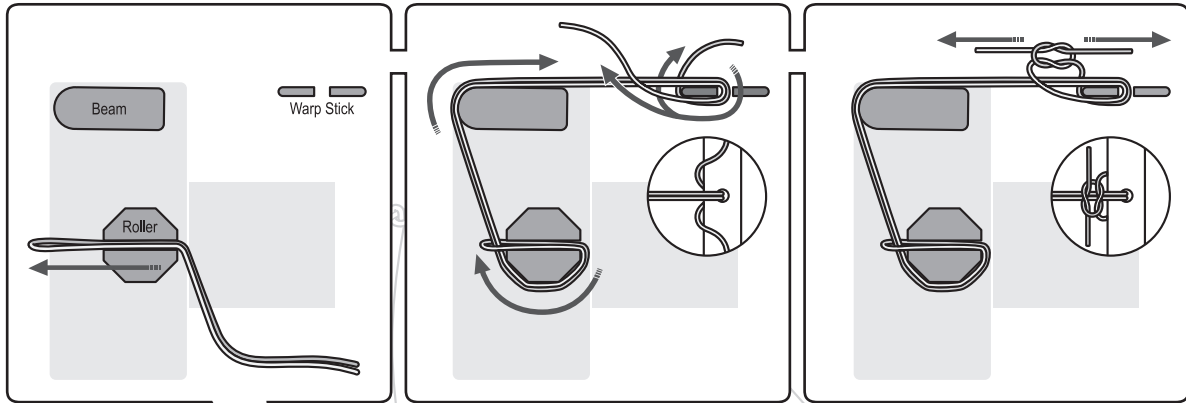

Tying on the back warp stick

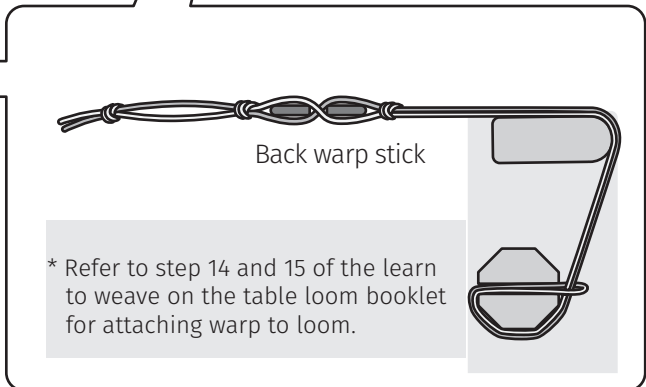
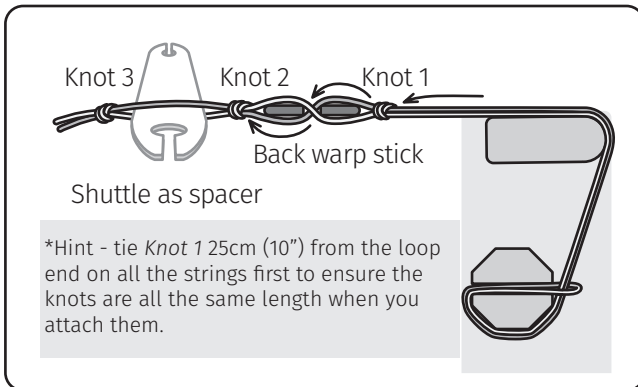

Check!

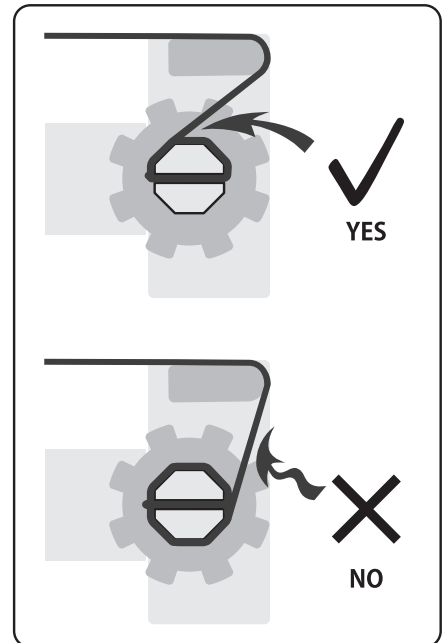

*Hints

To release the warp tension to advance the warp, turn the handle slightly and then lift the pawls on both ends out of the teeth. Lift all the heddle frames before folding.

Now follow the easy step by step "Learn to weave on the Table Loom booklet" for your first woven sample!

Happy weaving!

Real scale hardware list for Table Loom

