

## e-Spinner Super Jumbo

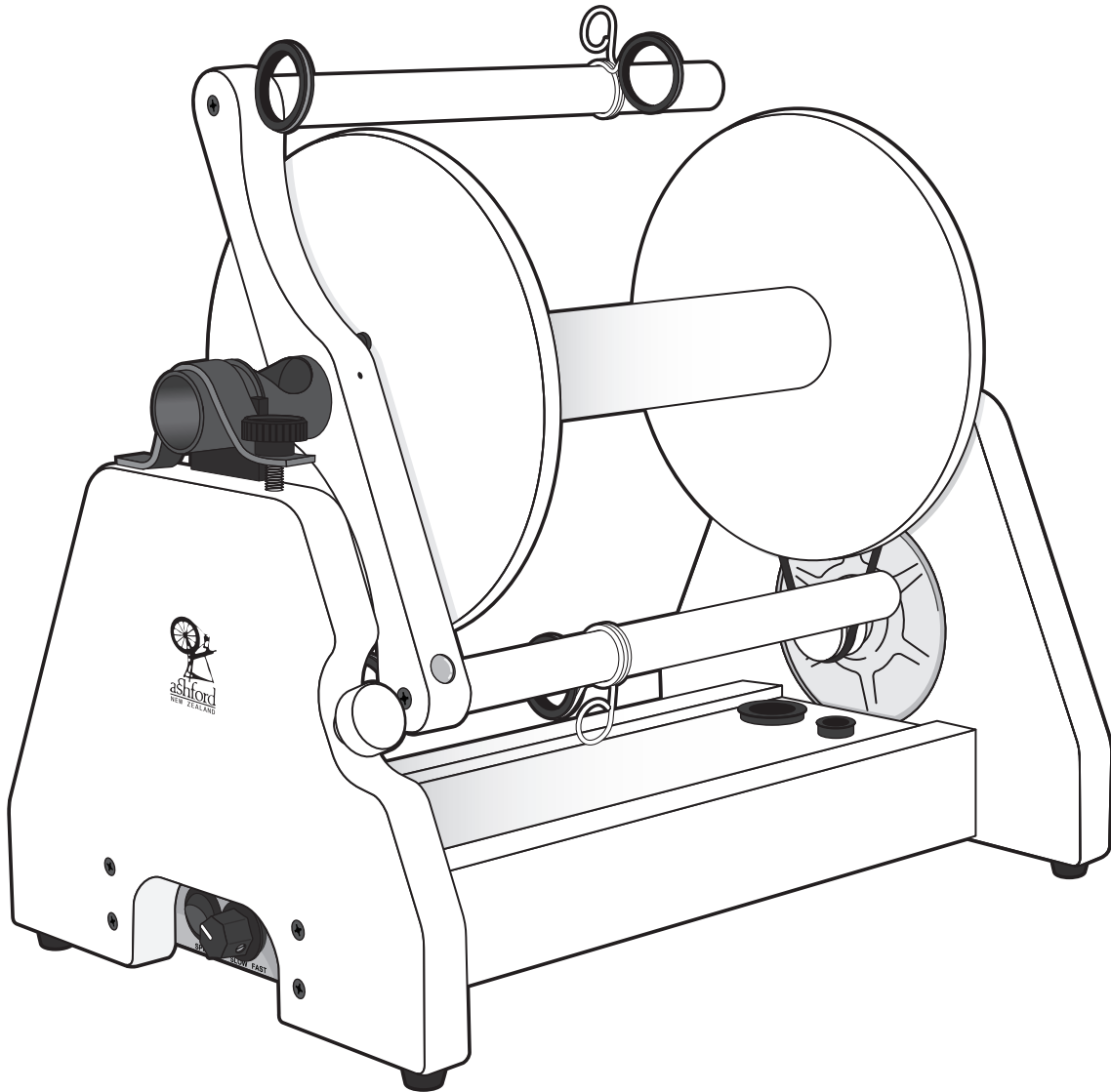

ESPSJ260423V5

### Ashford Guarantee

Thank you for purchasing this Ashford product. In the unlikely event there is any fault in manufacture, please contact the dealer you purchased it from. To validate the guarantee, please go to [www.ashford.co.nz/product-registration](http://www.ashford.co.nz/product-registration)

# ASSEMBLY INSTRUCTIONS FOR THE ASHFORD e-Spinner Super Jumbo

Before commencing, please read these instructions completely, identify the parts and note the assembly sequence.

## Finish

Your e-Spinner Super Jumbo has been lacquered prior to assembly. If desired Ashford Finishing Wax Polish may be applied to further enhance its appearance.

## Lubrication

- We recommend Ashford Spinning Wheel Oil be regularly applied to the front and rear flyer and bobbin bearings.
- The bobbin and flyer must revolve freely and independently of each other.
- The ball bearings in the motor may be noisy for the first 5-10 minutes as they “run-in” and the grease is dissipated evenly.



## Assembly

1. Locate the two Orifice Reducer Bushes into the holes in top of the base.
2. Locate the threading hook into the tapered hole in the front. This will only be required when using the Orifice Reducer Bushes.



Orifice Reducer Bushes

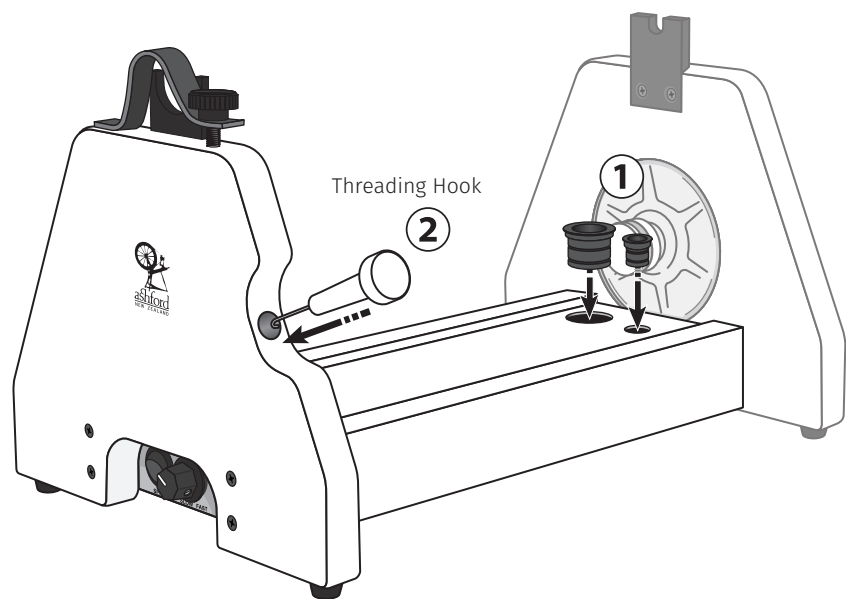

3. Squeeze and slide the stainless-steel yarn guides onto opposite sides of the flyer arms.  
NOTE: when spinning at higher RPM it may be necessary to squeeze and rotate whichever yarn guide isn't being used to achieve perfect balance.
4. Apply a drop of oil to the flyer spindle and slide the bobbin on.

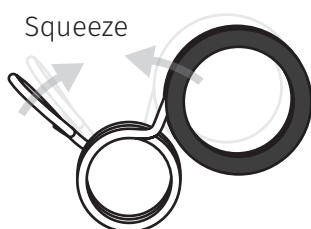

Yarn Guide

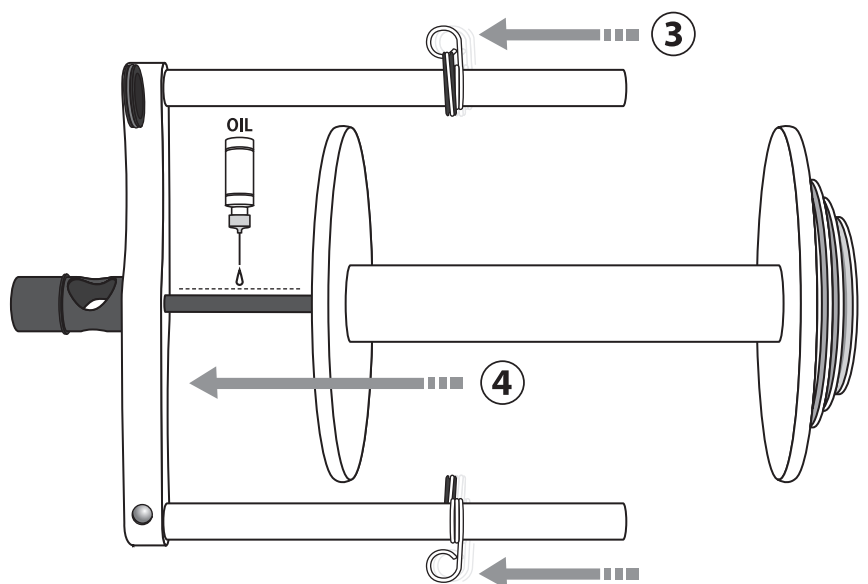

5. Locate the drive band onto the MIDDLE groove in the bobbin whorl. Do not use the large groove as this will stretch the drive band. We have used the Country Spinner2 Bobbin as standard on the e-Spinner Super Jumbo, so they are interchangeable between the two spinning wheels.

## Check!

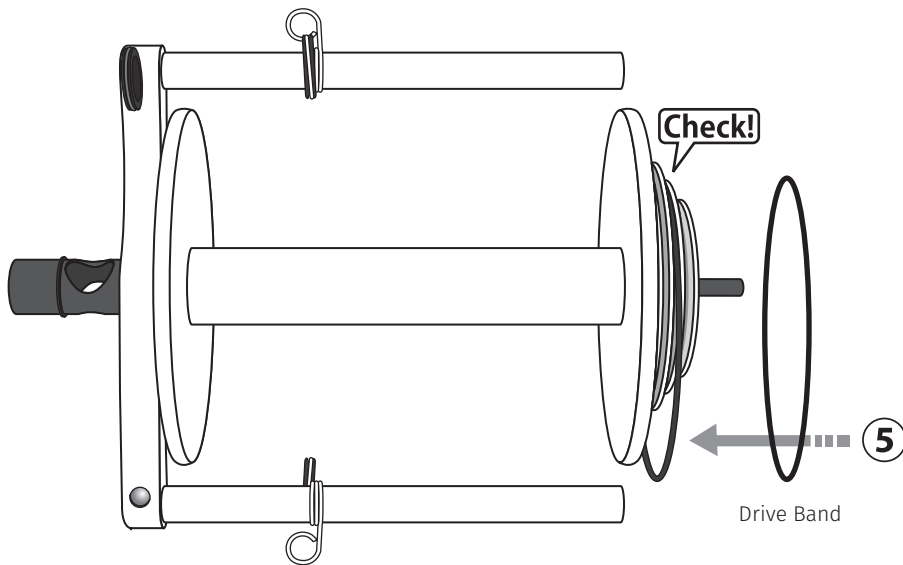
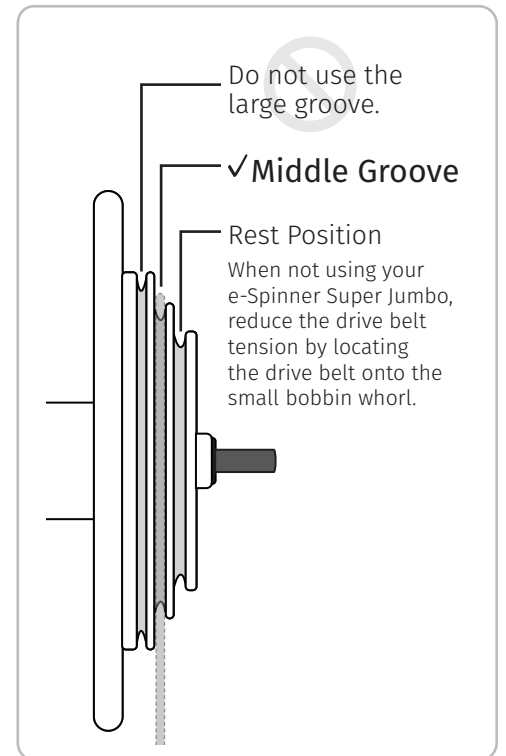

6. Apply a drop of oil to the front of the flyer shaft. Position the flyer under the leather brake band and into the front and rear flyer bearings.

7. Carefully stretch and roll the drive band onto the motor pulley.

8. Turn the tension knob so the leather brake band is quite loose. Under most spinning conditions the leather brake band should be loose.

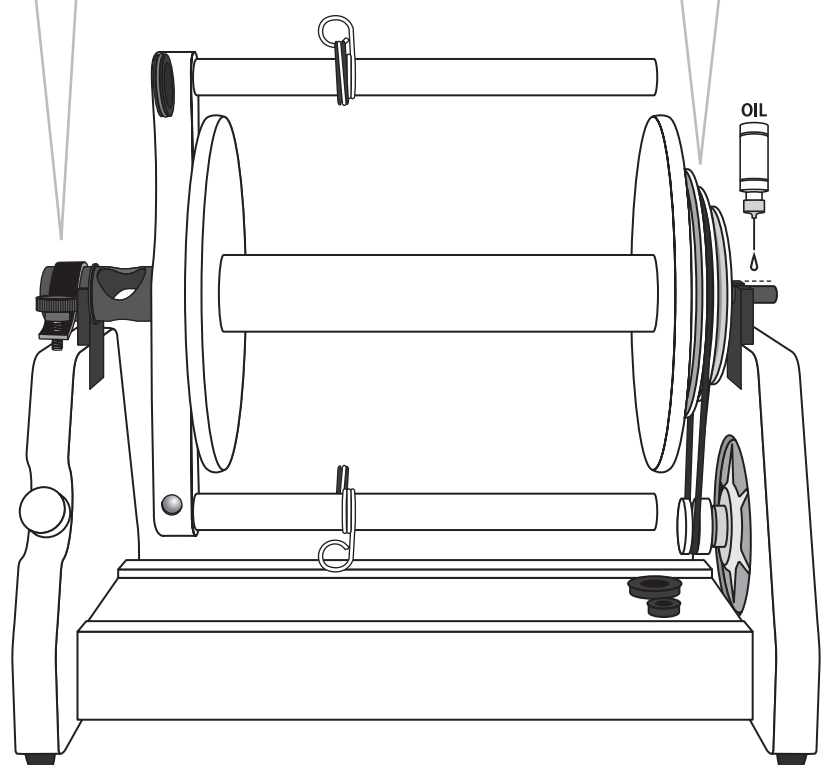
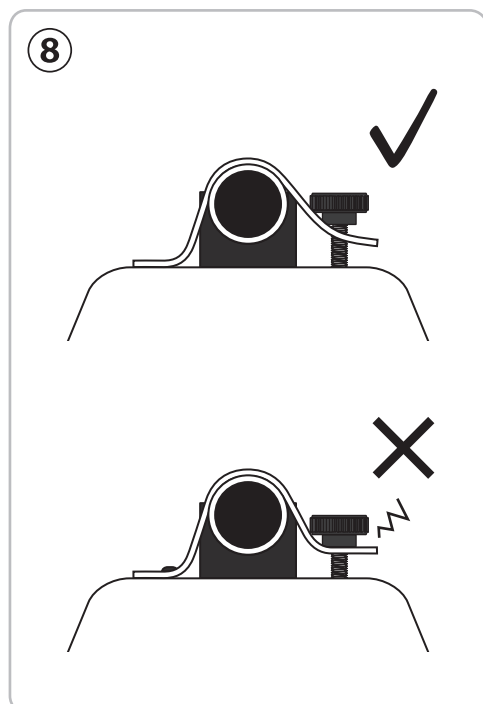
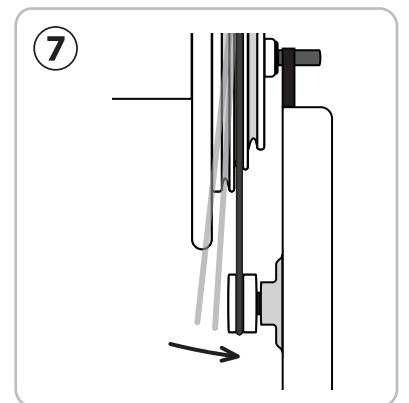
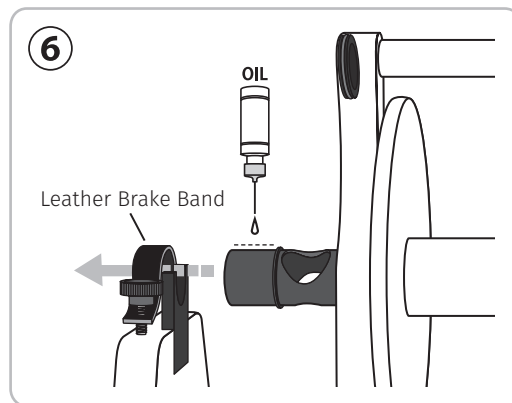

# 100-240V AC/DC Adapter

Plug the 100-240V AC/DC adapter into an appropriate wall socket and the plug into the 12V INPUT hole in the back of the e-Spinner Super Jumbo.

## Control Panel

**Z TWIST/S TWIST (Clockwise/Anticlockwise)**  
Z TWIST is for spinning, S TWIST is for plying. Do not reverse the direction without stopping the motor with the ON/OFF switch.

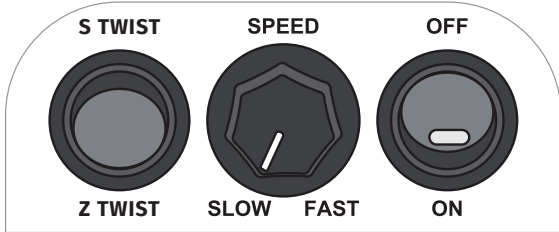

**SPEED**  
Start on SLOW and turn the dial clockwise to gradually increase the speed until the desired RPM is reached.

### ON/OFF

The e-Spinner Super Jumbo is fitted with a soft start which results in the motor taking 2-3 seconds to reach the desired speed. This prevents the yarn being jerked out of your hands when starting. When you want to stop always switch the e-Spinner Super Jumbo OFF rather than using the speed control. Check the red LED light is off before you leave your e-Spinner Super Jumbo.

### LED Light

The Red LED light indicates the status of your e-Spinner Super Jumbo.

### Constant On

The e-Spinner Super Jumbo is running normally.

### Flashing short on/short off

The e-Spinner Super Jumbo is on standby. The speed is set to ZERO or the foot switch is OFF.

### Flashing long on/short off

The AC/DC adapter is under load. This is OK, and you can't harm the e-Spinner Super Jumbo. However, we recommend you apply a drop of oil to the flyer and bobbin bearings, reduce the brake band tension and reduce speed until the flashing stops.

## Foot Switch

If you would like to START and STOP your e-Spinner Super Jumbo with the foot switch only, insert the foot switch plug into the FOOT SWITCH hole in the back of the e-Spinner Super Jumbo. There are two operating modes.

### Recommended Mode



Turn the ON/OFF switch to ON.

#### START

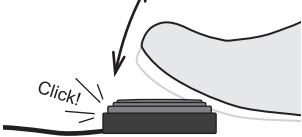

#### STOP



Lightly tap the foot switch to turn the e-Spinner Super Jumbo ON and lightly tap again to turn it OFF.

### Alternate Mode



Lightly put your foot on the foot switch and turn the power ON.

#### ON

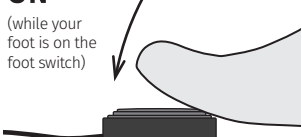

#### OFF



The e-Spinner Super Jumbo will operate only while your foot is on the foot switch. Lift your foot off and the e-Spinner Super Jumbo will stop.

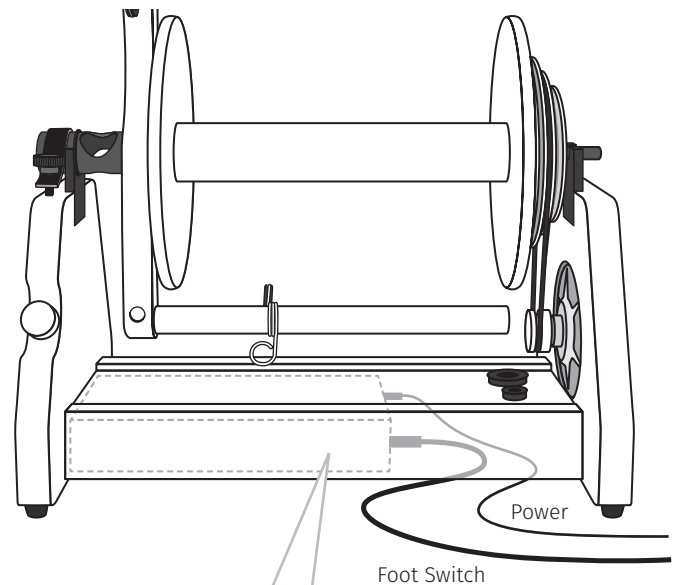

**NOTE:** ensure the e-Spinner Super Jumbo is switched OFF before removing the foot switch plug.



**IMPORTANT:** Avoid tripping over or yanking on the foot switch or AC/DC adapter cords as this can damage or break the plugs and void your warranty. Please remove both cords when transporting your e-Spinner Super Jumbo.

# Spinning

Because the e-Spinner Super Jumbo is bobbin lead the yarn needs to be strong enough to turn the flyer. Thus, it requires very little tension on the leather brake band. At full speed the flyer rotates at approx. 500 RPM.

1. Tie a piece of medium to thick wool yarn called a leader, approx. 1.5m (5 feet) long to the bobbin. Thread it through the flyer yarn guides with the black inserts on the **left-hand side of the flyer** and out through the orifice.

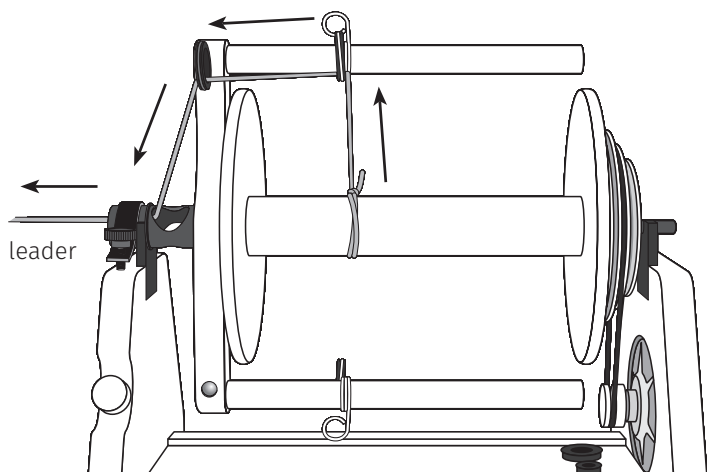

2. Have your prepared fibres ready to spin.
3. Unwind the tension knob until the leather brake band is loose.
4. Check the S TWIST/Z TWIST switch is on Z TWIST (down) and the SPEED control is on SLOW. Switch the ON/OFF switch to ON. Gradually turn the SPEED control clockwise until the flyer starts to turn slowly.

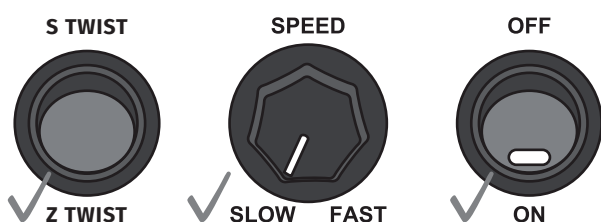

5. Allow the leader to start feeding in and commence drafting your prepared fibres onto it. Initially try to spin a thick yarn keeping your hands close to the flyer orifice.
6. Adjust the SPEED control and tension knob to achieve a comfortable speed and take up.

- If your yarn breaks, draft a thicker yarn, increase the speed a little, reduce the brake tension and oil the bearings.
- If your yarn kinks, is over twisted or won't feed on, reduce speed and increase the brake tension a little.
- Use the ON/OFF switch or foot switch (rather than the speed control) to stop the motor when moving the position of the yarn guides. This will ensure you recommence at the same speed.

## Changing the bobbin

- Turn the motor off using the ON/OFF switch or foot switch.
- Remove the drive band from the motor pulley.
- Slide the bobbin off the flyer spindle.
- Apply a drop of oil to the spindle and fit another bobbin. Locate the drive band onto the MIDDLE groove in the bobbin whorl. Do not use the large groove as this will stretch the drive band.
- Apply a drop of oil to the front of the flyer shaft. Position it under the leather brake band and into the front and rear flyer bearings.

## Orifice Reducer Bushes

- Use the large Orifice Reducer Bush to reduce the orifice from 27mm (1 1/8") to 15mm (5/8") for spinning medium yarns.
- Use the small Orifice Reducer Bush to reduce the orifice to 9mm (3/8") for spinning fine yarns.
- Orifice Reducer Bushes help prevent the yarn vibrating. By drafting the yarn at about a 45-degree angle to the orifice the vibration will almost be eliminated.
- When not in use store the bushes in the holes in top of the base.
- Apply Vaseline to the o-ring to make them easier to insert or remove.

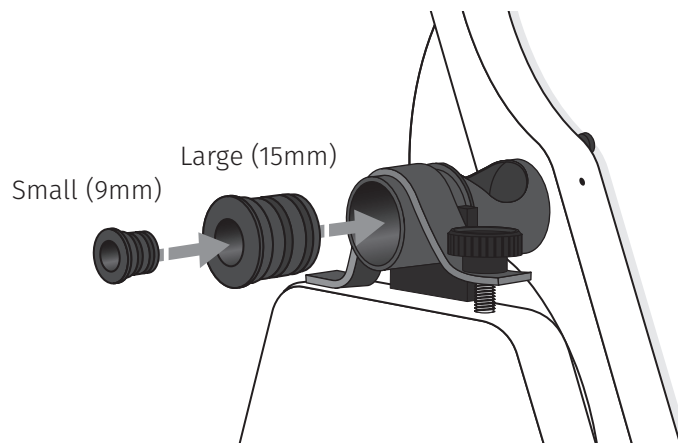

## Lubrication

We recommend Ashford Spinning Wheel Oil be regularly applied to the front and rear flyer and bobbin bearings.

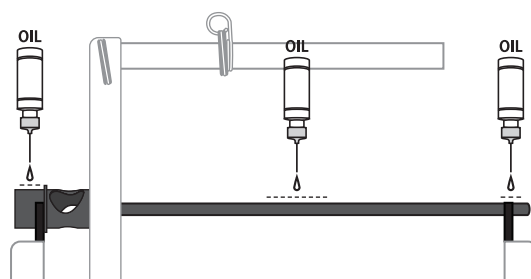

# Plying

1. Thread the leader through the flyer yarn guide with the black inserts and out through the orifice. Locate 2 bobbins of spun yarn onto the pins of the optional Lazy Kate and tie the two strands of yarn to the leader.
2. Check the S TWIST/Z TWIST switch is on S TWIST (up) and the SPEED control is on SLOW. Switch the ON/OFF switch to ON. Gradually turn the SPEED control clockwise until the flyer starts to turn slowly.

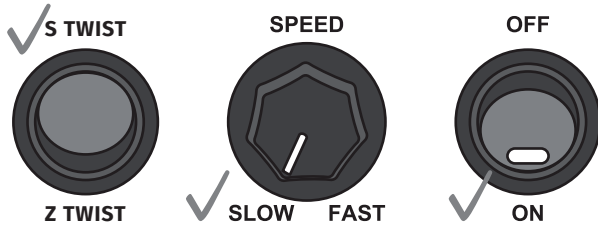

3. Allow the leader and your spun yarn to start feeding in. Use the least amount of leather brake band tension possible.

## Safety

1. Take care to ensure children and pets are always well clear of the e-Spinner Super Jumbo when starting or while it is in use.
2. Always unplug the AC/DC adapter from the wall when not in use.
3. Never leave the e-Spinner Super Jumbo without switching it OFF at the ON/OFF switch.
4. Ensure the e-Spinner Super Jumbo is switched off before removing the foot switch plug.
5. Do not use your e-Spinner Super Jumbo in damp or wet conditions.
6. Never open the electronic compartment without first disconnecting it from the power supply.
7. Use the padded carry bag to protect your e-Spinner Super Jumbo, Lazy Kate, AC/DC adapter and foot switch when not in use or travelling.

For further plying information refer to "The Ashford book of Hand Spinning" by Jo Reeve, a 116-page book full of ideas and inspiration for spinners.

## Accessories - Available from your local Ashford Dealer.

### 12V cigarette cord

so you can spin away from home in your car, caravan, RV, boat or using a battery pack.



### Bobbins

Ashford Country Spinner2 bobbins.



### Lazy Kate

Bobbins not included.



### Padded Carry Bag - included

Store your e-Spinner Super Jumbo in the convenient padded carry bag. The AC/DC adapter, foot switch and oil bottle will fit in the handy pockets.



## More Information



**How-to videos on You Tube**  
Watch our how-to videos on You Tube.  
@AshfordNz



**Facebook**  
Join us on facebook Ashford.Wheels.Looms



### The Wheel Magazine

Ashford's annual fibre craft magazine. Spinning, weaving, felting, dyeing and knitting projects, patterns and articles from around the world. To receive the premium version delivered to you, subscribe at:  
[www.ashford.co.nz/subscribe](http://www.ashford.co.nz/subscribe)